

**Grant County
Public Utility
District No. 2**



**ELECTRIC SYSTEM
and
FIBER OPTIC
DESIGN and CONSTRUCTION PROCEDURES
for both
RESIDENTIAL and COMMERCIAL SUBDIVISIONS
and
MOBILE HOME PARK
DEVELOPMENTS**

REVISED: August 2024

UNDERGROUND DESIGN & CONSTRUCTION PROCEDURES

TABLE OF CONTENTS

S Section One – General Information----- 8

8 Introduction: ----- 8

Owner/Developer Responsibility: ----- 8

Grant PUD Design Acceptance: ----- 8

Section Two – Right-of-Way----- 9

General Information ----- 9

Land Use Requirements----- 9

Compliance with other Agencies----- 9

Provide Copies to Grant PUD----- 9

Property Corners ----- 9

Easements for Rights-of-Way ----- 9

Public Agency Permits/Licenses for Rights-of-Way ----- 9

City Permits ----- 9

Grant County Road Permits ----- 9

Lincoln County Road Permits ----- 9

Columbia Basin Irrigation District Permits ----- 10

Washington State Department of Transportation (WSDOT) Permits ----- 10

Washington Department of Natural Resources (DNR) Easements ----- 10

Bonneville Power Administration (BPA) Permits----- 10

United States Bureau of Reclamation (USBR) Licenses----- 10

Bureau of Land Management (BLM) Easements ----- 10

Railroad Permits----- 10

Grant PUD Responsibility ----- 10

Customer Responsibility ----- 10

Section Three – Electrical and Fiber Optic System Process:----- 11

Owner/Developer Requirements:----- 11

Owner/Developer Supplied Material: ----- 12

Owner/Developer Installation:----- 13

Grant PUD Supplied Material & Equipment ----- 15

Design Information: ----- 15

Electronic Drawing Information: ----- 15

<i>Electric System:</i> -----	16
<i>Underground Schematics:</i> -----	18
<i>Street Lighting:</i> -----	18
<i>GCPUD Fiber Optic System:</i> -----	19
<i>Specific by Sheet Design Information for Electrical and Fiber Optic Layouts:</i> -----	19
<i>Deliverables:</i> -----	23
SAMPLE DRAWINGS -----	24
GCPUD CONSTRUCTION STANDARDS -----	38
ASSEMBLY UNITS -----	55
STOCK PAGES -----	57

Chapter One – General Information

Introduction:

This packet provides information for Owners/Developers to install overhead and underground facilities within their platted subdivision, master planned resort, planned unit development, binding site plan or any other development and/or segregation of land as approved by the county and/or city planning department. This includes Grant PUD's requirements for electrical design, fiber optic design, quality assurance, and construction standards. In addition, this packet covers right-of-way requirements, vault and conduit locations and placement, and street light design. It is intended to guide the Owner/Developer and his Design Engineer through the design process. Deviation from these guidelines must be pre-approved in writing by Grant PUD's Engineering Technician. As always, Grant PUD's Customer Service Policies as written or amended, and all applicable national, state and local codes take precedent over these guidelines.

Owner/Developer Responsibility:

The Owner/Developer is responsible for the entire design, right-of-way and/or right-of-way acquisition, staking, construction, and project management. This includes compliance with all land use requirements within the city and/or county and all code, permit, and right-of-way requirements required by the jurisdictional agencies.

An overlay of all utilities is mandatory to assure proper clearances. All utilities that are installed within the boundaries of the development need to be designed so that adequate clearances as required by Grant PUD and all other agencies are maintained. The owner/developer shall coordinate the design and installation with all utilities so that conflicts are minimal or non-existing.

Refer to Section Three for full Owner/Developer Responsibility.

Grant PUD Design Acceptance:

Grant PUD will not accept any design unless it meets the following guidelines & design criteria. If there are deficiencies, Grant PUD will give the Owner/Developer a list of deficient items. Construction will not be approved until all deficiencies have been rectified to the satisfaction of the Grant PUD and approved by Grant PUD's Engineering Technician.

The Owner/Developer shall also ascertain that all conflicts with the installation of other utilities (phone, TV, water, sewer, gas, Etc..) have been rectified. Grant PUD **WILL NOT** continue installation of their facilities or provide service to future customers until all deficiencies are corrected to Grant PUD's satisfaction.

Section Two – Right-of-Way

General Information

This chapter covers Grant PUD's requirements and the Customer's responsibilities for land use requirements, rights-of-way and permits. An Engineering Technician will be assigned to any "Line Extension project" that requires additional rights-of-way and/or permits.

Land Use Requirements

The customer shall comply with the following land use requirements for both the electric system and the fiber optic system.

Compliance with other Agencies

The Customer will be required to comply with all applicable jurisdictional agencies, state, county, and local statutes. These shall include, but not necessarily be limited to, the County Unified Development Code, Uniform Building Code, Urban Growth Management Area development standards, and regulations requiring certain minimum improvements.

Provide Copies to Grant PUD

The customer shall provide Grant PUD with executed copies of any and all required agency developmental approvals, i.e. approved building site plan.

Property Corners

Property corners that are disturbed shall be replaced by the owner. Property corners shall not be driven deeper than 18 inches below final grade in order to protect buried facilities.

Easements for Rights-of-Way

The customer shall complete the "Service Connection Agreement" with the names of legal landowners, property description(s), and sketch showing all property boundaries that the service connection will affect.

The customer is required to obtain the property owner's signature on the "Service Connection Agreement" in order for Grant PUD to install facilities on the property.

Grant PUD will determine if additional easements for rights-of-way are required. Grant PUD will prepare all easement documents on Grant PUD easement templates and the Customer shall obtain all property owners' signatures. **Grant PUD's cost for preparing the easement(s) for rights-of-way will be a flat fee of \$100.00 per easement.** The assigned *Engineering Technician* will advise the customer of the required fees.

Once the *easement(s)* for rights-of-way are signed by the property owner(s) and notarized in the presence of a Notary Public, return them to Grant PUD: Attention; Lands Department – Distribution Right-of-Way. Grant PUD will record the *easement(s)* at the respective Auditor's Office of the appropriate county, i.e. Grant, Lincoln, Adams, Douglas, etc.

Public Agency Permits/Licenses for Rights-of-Way

Grant PUD will obtain the required permits/licenses from public agencies or entities (WSDOT, USBR, BLM, DNR, Railroads, Cities, etc.).

The customer shall pay for any or all permits/licenses, including but not limited to, Washington State Department of Transportation, United States Bureau of Reclamation, United States Bureau of Land Management, Washington State Department of Natural Resources, Railroad, and other *permits/licenses* as may be required along with any required professional surveys.

City Permits may be required if Grant PUD's electrical wires, fiber optic cables or conduits are constructed within city limits. Depending on the city a fee may be required. A minimum of two weeks is required to obtain permit(s).

Grant County Road Permits are required if Grant PUD's electrical wires, fiber optic cables or conduits cross over or under a county road. A minimum of two weeks is required to obtain permit(s).

Lincoln County Road Permits are required if Grant PUD's electrical wires, fiber optic cables or conduits cross a county road. The cost usually varies from \$75 to \$150, and is subject to change. A minimum of four weeks is required to obtain the permit(s).

Columbia Basin Irrigation District Permits are required if Grant PUD's electrical wires, fiber optic cables or conduits cross over or under an irrigation district waterway. These permits will be obtained by Grant PUD from the appropriate irrigation district (i.e. South Columbia Basin Irrigation District, Quincy Columbia Basin Irrigation District, or East Columbia Basin Irrigation District.) A minimum of three weeks is required to obtain permit(s).

Washington State Department of Transportation (WSDOT) Permits are required if Grant PUD's electrical wires, fiber optic cables or conduits cross over or under a state highway or parallel a state highway within their right-of-way and easement. There is a fee for this permit, usually ranging in cost from \$150 to \$500, and is subject to change. A minimum of four to six months is required to obtain the permit(s).

Washington Department of Natural Resources (DNR) Easements are required if Grant PUD's electrical wires, fiber optic cables or conduits cross over or under DNR property. To obtain this permit a professional survey is required at the customer's expense. Grant PUD will obtain the survey and the permit. The DNR charges a minimum of \$1,000 (subject to change) for the costs of the permit. Upon completion of the survey, the survey and application fee will be submitted to DNR for processing and approval. A minimum of three to four months is required to obtain permit(s). DNR tenants will not be required to obtain a permit; however, DNR must approve and sign the tenant's Service Connection Agreement.

WDNR tenants are required to obtain an easement.

Bonneville Power Administration (BPA) Permits are required if Grant PUD's electrical wires, fiber optic cables or conduits cross under a BPA power line or are located in the BPA easement area. A minimum of twelvemonths is required to obtain permit(s).

United States Bureau of Reclamation (USBR) Licenses or Consent to Use are required if Grant PUD's electrical wires, fiber optic cables or conduits cross over or under USBR property. The USBR charges \$3000 (subject to change) and a percentage of Fair Market Value for this license. A minimum of eighteen months is required to obtain license(s).

Bureau of Land Management (BLM) Easements are required if Grant PUD's electrical wires, fiber optic cables or conduits cross over or under BLM property. To obtain this permit, an application and permit fee must be submitted to BLM. The permit fee ranges from \$175 to \$1,156, and is subject to change. A minimum of three months is required to obtain easement(s).

Railroad Permits are required if Grant PUD's electrical wires, fiber optic cables or conduits cross over, under or parallel to the railroad track. The cost for a permit from Burlington Northern Santa Fe Railroad is \$3,800 and the cost for a permit from Washington Central Railroad is \$3,700 (*either fee is subject to change*). A minimum of four months is required to obtain permit(s). Any other fees associated with obtaining these permits will be charged to the Customer.

Grant PUD Responsibility

Prepare the easement documents for rights-of-way. Determine what easements for rights-of-way are required and prepare legal documents for signatures. Receive the signed and notarized easement(s) for rights-of-way from the Customer. Record the signed and notarized easement for rights-of-way at the designated County Courthouse. Obtain all required permits for rights-of-way to facilitate construction of Grant PUDs electrical and fiber optic equipment including coordinating the required professional surveys. The Customer may choose to provide a professional survey to save cost and/or time. Grant PUD will acquire the permit for right of way from other agencies and pass on the fees associated with the permits.

Customer Responsibility

Obtain appropriate signatures on Grant PUD prepared easement forms for rights-of-way. All easements and permits for right of way must be, notarized, and received by Grant PUD prior to any construction. Obtain any permits or easements for rights-of-way that may be required for the Customers own equipment, construction, access, etc. Pay for State Highway Permits, United States Bureau of Reclamation Permits, Bureau of Land Management, Department of Natural Resources Permits, and Railroad Permits and their required professional surveys. Pay a legal documentation preparation fee to Grant PUD for easements and rights-of-way.

Section Three – Electrical and Fiber Optic System Process:

Owner/Developer Requirements:

From an approved preliminary plat or other development plan, the Owner/Developer shall be responsible for the design and installation of the underground electrical & fiber optic system. The Owner/Developer shall be responsible for all coordination from beginning to end of the project including but not limited to: utility staking, road crossing placement, material and construction inspection. The following steps will assist the Owner/Developer during the planning, design, and construction stages of the project.

Step 1: Owner(s)/Underlying fee owner shall be required to execute a Grant PUD Service Connection Agreement and return said document to Grant PUD's Service Expediter. serviceexpediter@gcpud.org

Step 2: Owner/Developer shall secure the services of a Design Engineer or Engineering firm licensed in the State of Washington in accordance to WAC and RCW requirements.

Step 3: The Owner/Developer shall schedule a preliminary plan review with Grant PUD's Engineering Technician to obtain the required information necessary to design the electric and fiber optic system.

Step 4: The Owner/Developers Design Engineer shall design and layout the complete electrical and fiber optic distribution systems to Grant PUD's design specifications. The design shall be shown in relation to all other utilities and be free from conflicts.

Step 5: Submit preliminary design drawings to Grant PUD's Engineering Technician for review and approval.

Step 6: Work with Grant PUD's right-of-way staff to complete and submit all needed easements and permits as outlined in section two of this document. All easements shall be to the GCPUD only.

Step 7: The Owner/Developer shall obtain from the appropriate city/county agency, directives for street lighting installations. Per the GCPUD customer Service Policy and per IEEE standard street lighting design criteria, if so required.

Step 8: After Grant PUD approves the design and design drawings:

- a) A professional Engineer shall stamp all drawings per WAC and RCW requirements.
- b) Furnish four (4) complete sets of stamped drawings marked "Approved for Construction" in a "B" size (11"x17") format along with one (1) electronic copy of the design in an AutoCAD format. These are to come from the Engineer or Engineering firm that completed the design.
- c) Coordinate w/ other utilities (Telephone, Cable TV, & Natural Gas)
- d) Furnish a construction schedule to Grant PUD's Engineering Technician.
- e) Schedule an on-site pre-construction meeting with Grant PUD's Engineering Technician, Inspector and the owner/developers construction foreman.
- f) Furnish to Grant PUD's Engineering Technician and Inspector a complete list of material for owner/developer furnished material along with a list of all vendors.

-The Owner/Developer should contact the Engineer/Engineering firm with any questions specifically about the design.

Step 9: Using the "Approved for Construction" drawings Grant PUD's Engineering Technician will prepare a cost estimate for Grant PUD furnished labor, material, and equipment. **THE ESTIMATE MUST BE PAID IN FULL PRIOR TO ANY ELECTRICAL CONDUCTOR BEING INSTALLED AND ENERGIIZED.**

Step 10: Grant PUD shall inspect and approve all material prior to installation. **MATERIAL USED AND OR PLACED BEFORE INSPECTION SHALL BE SUBJECT TO REPLACEMENT AT THE OWNER/DEVELOPER'S COST.**

Step 11: Proceed with the installation of the electrical and fiber optic vault and conduit system, street light circuits, secondary pedestals, transformer pads, switching vaults, and switchgear vaults.

Step 12: Schedule Grant PUD inspection(s) prior to covering/backfilling vault and conduit systems. Repair and/or replace any item that does not meet Grant PUD standards or specifications. **ITEMS NOT INSPECTED, PRIOR TO COVERING/BACKFILLING, SUBJECT TO THE OWNER/DEVELOPER TO ADDITIONAL COSTS FOR INSPECTIONS.**

Step 13: Furnish “As-Built” drawings of the Owner/Developer installed vault and duct system. If there are no “As-Builts” furnish a set of drawings marked “No Change”.

Step 14: Grant PUD will schedule its work after receiving the payment, As-Builts, and after completion of the Owner/Developer portion of the project.

GRANT PUD WILL NOT SCHEDULE ANY WORK UNTIL THE ESTIMATE HAS BEEN PAID, ALL EASEMENTS, PERMITS AND ANY OTHER AUTHORIZATIONS HAVE BEEN RECEIVED AND THE AS-BUILTS HAVE BEEN RECEIVED.

IF DURING THE GCPUD INSTALLATION PROCESS, THERE ARE DEFECTIVE OR INFERIOR MATERIALS DISCOVERED OR IF THE WORK PRACTICES OF THE CONTRACTOR ARE FOUND TO BE DEFICIENT EVEN AFTER THE INSPECTION PROCESS, THE COST OF REPLACEMENT OR RE-WORK WILL BE AT THE OWNER’S EXPENSE.

Owner/Developer Supplied Material:

All materials shall comply with Grant PUD’s most recent specifications or be pre-approved by Grant PUD’s Standards Department.

a) Trenching, Bedding and Backfill

Developer is responsible for all excavation, bedding and backfilling per Grant PUD specifications, which are included in this document. See Grant PUD Standard No. 10.0008.

b) Conduit

- Refer to “Conduit Standards for Customer Service Workbooks”, which is part of this document.
- Electrical conduit shall be gray Schedule 40 rigid PVC or rigid steel as listed in the attached specifications for design work.
- Acceptable conduit diameters shall be limited to 2, 3, 4, or 6 inches.
- Conduit sweeps shall be 24, 36, or 48 inch radius, as specified or approved by the Engineering Design Technician.
- All conduit and sweeps will be provided by the Owner/Developer.

c) Transformer Box and Pad

The developer shall supply transformer concrete vaults and pads, per Grant PUD standards and specifications.

d) Switching Vaults

The developer shall supply all concrete switching vaults, per Grant PUD Standards and specifications.

e) Barriers

Suitable barriers shall be supplied by the Owner/Developer similar to Grant PUD’s material stock page no. 83271800 or a barrier approved by Grant PUD’s Engineering Technician.

f) Secondary Mopeds/Pedestals

Pedestals per Grant PUD standards and specifications shall be supplied by the developer.

g) Fiber Optic Conduit, Vaults, and Hand-holes

All fiber optic conduit, vaults, and hand-holes for Grant PUD fiber optic cable shall be supplied by the Owner/Developer.

h) Material Inspection and Quality Assurance

All materials shall meet Grant PUD's QA standards. Vaults, transformer vaults and lids shall be inspected and approved by Grant PUD prior to placement. QA of vaults are of particular concern. It should be noted that some suppliers might be temporarily taken off Grant PUD Standards due to QA concerns. The design Engineer needs to contact Grant PUD's Standards Department to see if vendors are still approved.

Owner/Developer Installation:

All material(s) shall be installed to Grant PUD standards and specifications and within the following parameters:

a) Trenching, Bedding and Backfill

- Developer is responsible for all excavation bedding and backfilling per Grant PUD specifications, which are included in this document. See Grant PUD Standard No. 10.0008.
 - If final grade has been changed after Grant PUD inspection and installation and it affects either the electrical or fiber optic system, it will be at the expense of the owner/developer to have the infrastructure raised or lowered.
- Open excavations shall be guarded per WAC requirements.
- Road and street crossings may be either trenched and backfilled, bored or pushed, whichever is acceptable to the governing agency.

b) Conduit

- Conduit shall be installed according to Grant PUD's "Conduit Standards for Customer Workbooks" and within the following parameters:
- All conduit shall be installed within Grant PUD's Easements and Rights-of-Way.
- Spare electrical conduits installed for future use shall be marked six inches from both ends with Electrical Markers or in some other form approved by Grant PUD's Engineering Technician. All ends shall be capped with non-permanent caps.
- Where conduit bends are required, they shall meet the requirements for cable pulling as required in Grant PUD's Conduit Specifications.
- Conduit locations entering transformer boxes, hand holes, and vaults shall be coordinated with Grant PUD's Engineering Inspector. Conduit shall extend 3 inches inside all vaults and manholes, be perpendicular to the side and have bell ends installed on all conduit ends. Do not glue Bell Ends inside vaults.
- All conduit runs shall have a steel mandrel pulled through them in order to clear out debris and locate damaged conduits. Any damaged conduits shall be repaired by the Owner/Developer. This shall be done prior to Grant PUD pulling cable.
- **THE OWNER/DEVELOPER WILL BE SUBJECT TO ADDITIONAL COST IF GRANT PUD'S CREWS EXPERIENCE DAMAGED OR BLOCKED CONDUITS.**

c) Manholes – Switching & Transformer Boxes

- Manholes and transformer boxes shall be installed within utility easements and adjacent to lot lines, unless otherwise specified by Grant PUD.
- All manholes, transformers, etc. shall be set to the grade established in the approved drawings. Adjustments to grade shall be pre-approved by Grant PUD's Engineering Technician or may subject the Owner/Developer to additional cost.

- Manholes and transformer boxes installed on sloping terrain shall be protected from erosion and earth movement.
- Manhole and transformer pads shall be set so that the transformer doors and switch cabinet/manholes are operable from the street side. All equipment shall have and maintain adequate clearances in accordance to the National Electrical Safety Code (NESC) & Washington Administrative Code (WAC) from the front and sides, and back for safe operation.
- If either a transformer or manhole is located where it is susceptible to vehicular contact, Grant PUD approved barriers shall be installed.
- Prior to equipment placement openings in transformer pads and switching manholes shall be covered for safety at time of installation.

d) Transformer Box and Pads

- All transformer boxes and pads shall be installed to Grant PUD Standards and Specifications. Refer to Grant PUD Standard No. 10.1130, “Concrete transformer Box Pad Installation”, which is part of this document for further information. All transformers shall be supplied and installed by Grant PUD.

e) Switching Vaults

- The owner/developer shall install all switching vaults to Grant PUD’s Standards and Specifications. All switchgear will be supplied and installed by Grant PUD.

f) Secondary Pedestals

- Secondary pedestals shall be installed to Grant PUD’s Standards and Specifications. Refer to Grant PUD Standard No. 10.1140 that is part of this document for more information.
- Pedestals shall be installed on easements and adjacent to property corners.
- Pedestals shall be installed 3.5 feet minimum on either side or back of, but not in front of the transformer.
- Pedestals shall have 3.5 feet minimum working clearance from designated “front” side.
- Pedestals shall be placed with the front facing away from the transformer to allow for the secondary conductor from the transformer to be brought into the pedestal in the rear. Refer to ‘Pedestal Construction Detail’ located on page 8 of the Exhibit Drawings.
- Conduits shall enter the Pedestal from the bottom with conduit elbows. No cutting of Pedestals will be permitted.
- If a Pedestal must be located where it is susceptible to vehicular contact. Protective barriers shall be installed.

g) Roadway Lighting

- The developer shall obtain a written request from the governing agency for street lighting requirements.
- Install 2-inch schedule 40 PVC conduit from the transformer pad vault to each street light hand hole according to Grant PUD’s Conduit Specifications attached to this document.
- Conduit shall enter the hand hole from the bottom.
- Install hand hole per “Detail Layout 2” and “Detail Layout 3”, which are included in this document.
- The developer shall furnish conduit from street light hand hole to steel pole standard, wood pole, or concrete pedestal for steel pole.

h) Individual Services

- For Individual Residence Service, see the “Residential service Workbook”. Contact the service expediter for a copy at 509-766-2501 or serviceexpediter@gcpud.org.

Grant PUD Supplied Material & Equipment

Grant PUD will supply primary and secondary conductors, transformers, switch cabinets, and Grant PUD owned streetlights. Grant PUD will install the above material and equipment in the vault and duct system supplied by the Owner/Developer at the Owner/Developer’s cost, provided all the criteria is met within these procedures. Grant PUD will supply all fiber optic cable in the vault and duct system supplied by the Owner/Developer.

Design Information:

Electronic Drawing Information:

Layer management will be used utilizing all of AutoCAD’s layer management tools. All entities will be placed on their correct layer.

All layers will be placed in a layer filter that will make it easier to distinguish sheet sets within model space. The following is a list of the filters to be used and the layers to be contained within each.

- a) Background
 - SV-LOTL-EXST-LIN - YELLOW – CONTINUOUS - DEFAULT
 - SV-LOTL-FUTR-LIN - YELLOW – CONTINUOUS – 0.20
 - SV-LOTN-EXST-TXT - CYAN – PHANTOM – 0.13
 - SV-RDRW-EXST-LIN - YELLOW – CONTINUOUS – 0.13
 - SV-RDRW-EXST-TXT - YELLOW – CONTINUOUS – 0.13
- b) Civil
 - All layers that contain the civil infrastructure.
- c) Electrical-OH
 - ED-CPOH-EXST-LIN - WHITE – CONTINUOUS - DEFAULT
 - ED-PPOL-EXST-BLK - WHITE – CONTINUOUS – DEFAULT
- d) Electrical-UG
 - ED-CPUG-EXST-LIN-1PH – WHITE – DASHED4 – 0.09
 - ED-CPUG-EXST-LIN-3PH - WHITE – DASHED6 – 0.09
 - ED-CPUG-1PH-FUTR-LIN - WHITE – CONTINUOUS – 0.40
 - ED-CPUG-3PH-750-FUTR-LIN - WHITE – CENTER4 – 0.40
 - ED-CPUG-3PH-FUTR-LIN - WHITE – DASHED6 – 0.40
 - ED-CSSU-FUTR-LIN - 94 – DASHDOT4 – 0.30
 - ED-FRAM-FUTR-LIN - WHITE – CONTINUOUS – 0.15
 - ED-LBL-CON-PRI - MAGENTA – CONTINUOUS – 0.30
 - ED-LBL-CON-SEC - 92 – CONTINUOUS – 0.30
 - ED-PADS-FUTR-BLK - WHITE – CONTINUOUS – 0.20
 - ED-PED-FUTR-BLK - 94 – CONTINUOUS – 0.20
 - ED-STLT-EXST-BLK - MAGENTA – CONTINUOUS - DEFAULT
 - ED-VAUL-FUTR-BLK - WHITE – CONTINUOUS - DEFAULT
- e) Fiber
 - ED-FIBER-FUTR-LIN - WHITE – DASHDOT4 – 0.40
 - EF-FVLT-FUTR-BLK - MAGENTA – CONTINUOUS - DEFAULT
 - EF-HHOL-FUTR-BLK - MAGENTA – CONTINUOUS - DEFAULT
 - EF-TEXT-DIM - MAGENTA – CONTINUOUS - DEFAULT
- f) Misc.
 - TBLOCK - YELLOW – CONTINUOUS - DEFAULT

- BORDER - 8 – CONTINUOUS - DEFAULT

The previously mentioned layers are to be used for construction design drawings only. The following layers are to be used for the schematic drawings only and are also listed on the sample schematic drawing with their corresponding use.

a) Schematic

- UGTEXT - MAGENTA – CONTINUOUS - DEFAULT
- A - RED – CONTINUOUS - DEFAULT
- B - BLUE – CONTINUOUS - DEFAULT
- C - GREEN – CONTINUOUS - DEFAULT
- UGSCHEM - WHITE – CONTINUOUS - DEFAULT
- DDINUMBER - WHITE – CONTINUOUS - DEFAULT
- WOHISTRY - MAGENTA – CONTINUOUS - DEFAULT

- OPEN-TXT - GREEN – CONTINUOUS - DEFAULT
- BORDER - YELLOW – CONTINUOUS - DEFAULT
- TBLOCK - 8 – CONTINUOUS - DEFAULT

Any layers that are used in paper space such as the layers used for text, borders, details and dimensions do not need to be placed in layer filters.

There shall be only one layout in each drawing with all subsequent layouts layered on top. The filters shall be used to control each layout in model and paper space.

There shall be no need to alter or add any layers to Grant PUD’s layer set. The only layer that shall deviate from the layers mentioned above will be layers that contain the civil infrastructure.

Electric System:

The Owner/Developer shall procure the services of a Design Engineer, registered in the State of Washington, to design the electric system from an approved plat in accordance with Grant PUD standards and specifications. The design shall incorporate the following items:

Design Criteria:

Plat Design Drawings:

- The Plat design drawing shall consist of a map base background, existing electrical facilities, and proposed new electrical facilities, routes and assembly unit framing.
- Different AutoCAD blocks shall be used to represent existing facilities and new facilities.
- In all designs separate drawings will be needed for the following:
 - Vicinity Map
 - Electrical Layout
 - Fiber Layout
 - Framing
 - Schedules
 - Underground Schematic
 - Construction Details
 - Combined Layout
- The framing and schedules can be placed on the same drawing as their associated layout as long as it all fits on a “B” size 11”x17” drawing and is clean and readable.

- e) Grant PUD will supply a handout and Disk or will deliver via email the following plat standards:
 - Drawing Template
 - Standard Border
 - Standard Blocks
 - Standard Details
- f) Remove needless entities from frozen layers and purge all unnecessary blocks, layers, text, text styles etc.. All custom fonts and text styles should be converted to RomanS only and the custom items deleted.
- g) Basic layout information will be given to the Design Engineer as to conduit requirements, size and number of underground cables per duct, etc. at the time of preliminary plan review.
- h) All electric facilities shall utilize the front lot line design. Front lot line design is along the main street in front of the lot(s). The layout shall include the vault and duct system, switch cabinets, pad-mounted transformers, above ground secondary pedestals, and service locations. PLEASE NOTE: The fiber optic cable system and the electrical system are complete systems unto themselves and shall be designed separately.
- i) Conduit design, and installation shall meet Grant PUD's Design Standard No. 10.0008, "Trench Construction, PVC Pipe".
- j) Elevations shall be shown on design drawings. The Owner/Developer will be responsible for any added expenses if Grant PUD needs to adjust, raise, or lower equipment to meet grade or clearances.
- k) Non-standard burial depths shall be pre-approved by Grant PUD's Engineering Technician and so noted on the design drawings.

Standard underground conductor make-up lengths - Primary Conductor locations:

- a) Dip pole:
Primary conductor make up will be the total height of the primary pole.
i.e. 40 foot, class 3 pole, make up length is 40 feet. 45 foot, class 2 pole, make up length is 45 feet.
- b) Single phase padmount transformer vault:
Primary conductor make up will be 10 feet into the transformer vault. Conductor make up will be 10 feet out of the transformer vault.
i.e. transformer at loc 1 to transformer at loc 2, with 100 feet between transformer vaults. $10 + 100 + 10 = 120'$.
- c) Three phase padmount transformer vault, three phase switching vault (4'x6') and three phase switchgear vault (U56G, U56SG, U56V):
Primary conductor make up will be 20 feet into the vault. Conductor make up will be 20 feet out of the vault.
i.e. 45 foot dip pole at loc 1 to switchgear at loc 2, with 100 feet between dip pole and switchgear vault. $45 + 100 + 20 = 165'$.

Standard underground conductor make-up lengths - Secondary Conductor loc's:

- a) Single Phase padmount transformer:
Secondary conductor make up out of the transformer vault will be 5 feet.
- b) Single Phase moped:
Secondary conductor make up into the moped will be 5 feet. Secondary conductor out of the moped will be 5 feet.
- c) Single Phase meter base (6 ft. max above ground) & mobile home meter base:
Secondary conductor make up into the meter base 10 feet.
- d) Single Phase or Three Phase Secondary riser on Primary or Secondary pole:
Secondary conductor make up on the rise pole will be the height of the pole.
i.e. 40 foot, class 3 pole, make up length is 40 feet. 25 foot, class 4 pole, make up length is 25 feet. Secondary riser on 45 foot primary pole to moped ten feet away is: $45 + 10 + 5 = 60'$

- e) Single Phase and Three Phase Hand hole (flush mount to ground elevation):
Secondary conductor make up into hand hole will be 5 feet. Secondary conductor make up out hand hole will be 5 feet.

Underground Schematics:

- a) An underground schematic is a three-line diagram, showing underground primary electrical facility designs.
- b) Underground schematics will include the transition from overhead to underground conductors, vaults, switch gear, transformers, transformer pads, transformer size, fuse size, switch rating, fault indicators, cable type, cable phasing, cable size, cable lengths, and cable tags.
- c) All schematics will be drawn on a “B” size (11”x17”) border provided there is clarity of detail. Schematics can be drawn on a “D” size (22”x34”) border or larger if needed. Consult Grant PUD’s Engineering Technician for assistance in determining border size.
- d) For schematic conductor lengths use the edge to edge distance (i.e. edge of vault to edge of vault) with no conductor make up added. Conductor lengths must match the distances contained within the plan drawing conductor schedule and must match the conduit length contained within the conduit schedule.
- e) All schematics must meet the criteria and be laid out as shown in the sample schematic supplied in this package.
- f) Schematics will be contained within their own drawing file. The border and schematic shall be drawn in model space only at 1:1 scale.
- g) When submitted all schematics must be submitted in **COLOR**, either in electronic or hardcopy form, any schematics submitted in black and white **will not** be accepted.
- h) If the design schematic is an addition to an existing schematic, three separate drawings must be submitted.
 - a. A before construction schematic (furnished by Grant PUD).
 - b. A design schematic which contains only the new portion.
 - c. An as-built schematic containing the design schematic added to the existing schematic. When adding to an existing schematic the design schematic scale must match the existing schematic scale.

Street Lighting:

General:

For qualified applicants, Grant PUD will provide and install a system of non-metered street lighting facilities for dusk to dawn operation. Conventional street lighting consists of transformers and overhead or underground secondary conductors with mast arms and luminaries mounted on wood or metal poles. Additional primary conductor and transformers shall be at the expense of the Owner/Developer in accordance to Grant PUD’s Line extension Policy, section 4.0 and monthly billing will be in accordance with Rate Schedule 6.

Qualified Applicants:

Qualified Applicants shall be a State, County, City, Public Agency, organization, and Homeowners Association (minimum of 5 Residences), that can contract with Grant PUD to provide street lighting.

Design for Qualified Applicants:

The layout and design of the street lights shall meet all criteria and directives set forth by the County/City that has jurisdiction over them. The construction and wiring shall meet all the requirements of applicable federal, state, and local codes. Under certain conditions break-a-way pole bases are required.

Controls for Qualified Applicants

The luminaries for the Multi-Tap, Cutoff optics shall be controlled by individual photo-cells. The Decorative Street Lights can be group controlled using a photoelectric control receptacle shorting block with a photoelectric control relay.

Design for Un-Qualified Applicants

Service to un-qualified Applicants (Applicants not utilizing Grant PUD Standards) will be considered a line extension and appropriate fees and charges will apply in accordance with Line Extension Policy, Section 4.0. The service will be metered and the Applicant will be responsible for the design, installation, and maintenance of the lighting system

GCPUD Fiber Optic System:

The Owner/Developer "Requirements and Procedures" are identical to the electrical-Owner/Developer requirements, except street lighting requirements. Application for the fiber system shall be made at the same time as application for the electric system.

GCPUD FIBER OPTIC CONDUITS ARE REQUIRED ON ALL PLATS.

Design Criteria:

- a) Each vault is capable of accommodating 12 services only. Any more than 12 services will require an additional vault.
- b) The fiber optic system shall incorporate street side arrangement with vaults set to grade for splicing and terminations.
- c) Grant PUD allows joint trench with fiber optic cable, see trenching and conduit details in the attached sample drawing.
- d) The Owner/Developer will supply all Orange PVC Conduit, Grey Conduit sweeps, Vaults, Handholes and other pertinent materials for their development. Owner/developer shall install all material as designed.
- e) Grant PUD will furnish and install fiber optic cable and splices in accordance to Grant PUD's fiber optic Customer Service Policies and build out schedule or as amended.
- f) All fiber optic facilities shall be installed within easements and rights-of-way. Refer to page 9 of the Exhibit Drawings.
- g) Fiber optic vaults and handholes shall be installed per Detail Layout 3 found in the section titled "Sample Drawings" in the Exhibit Drawings packet. They shall be on either side of but not in the front or back of the transformer pad, or vault.
- h) If fiber optic vaults or handholes must be located where susceptible to vehicular contact protective barriers shall be installed.
- i) Conduits shall enter the bottom of the fiber optic vault or handhole. No cutting of the vault or handhole is permitted.

Specific by Sheet Design Information for Electrical and Fiber Optic Layouts:

I) The cover sheet will contain the following:

- a) A list of assembly units and descriptions used in the design.
- b) The development name.
- c) The Section, Township and Range that the development will be in.
- d) A vicinity map as described on the example cover sheet.

- e) All typical road cross sections. If there is more than one cross section in the project they all must be included. If there is not enough room on the cover sheet, include them in the detail sheets with the most common or typical cross section included on the cover sheet as shown in the example.
- f) A sheet index.
- g) The “Call before you dig” (811 or 1-800-424-5555) shall be up to date and on the cover sheet.

II) The Electrical Layout will contain the following:

- a) North Arrow
- b) Legend
- c) Roads and Road Names
- d) Road Right of Way & Utility Easements
- e) Lot lines, with Lot and Block Numbers.
- f) All existing adjacent Overhead and Underground electrical facilities.
- g) All proposed new primary and secondary electrical facilities

- h) All locations will be numbered sequentially starting at location 1, all new facilities and sweeps will be numbered. Only primary locations will have sequential numbers, all secondary locations will be alpha-numeric, the numeric number will match the number on the primary structure and will be sequential alpha characters after. See the attached drawing package for examples.
- i) Street Lighting plan according to the specifications set forth by the appropriate County/City agency & in accordance with IEEE standards.
- j) The “Call before you dig” (811 or 1-800-424-5555) shall be up to date and contained on each sheet.

III) The Fiber Layout will contain the following:

- a) North Arrow
- b) Legend
- c) Roads and Road Names
- d) Road Right of Way & Utility Easements
- e) Lot lines, with Lot and Block Numbers.
- f) All existing adjacent Overhead and Underground fiber facilities.
- g) All proposed new fiber facilities.

- h) All locations will be numbered sequentially starting at a number rounded up to the nearest hundredth from the last electrical location. For instance, if the last electrical location is 75 the first location for the fiber layout will be location 100, all new facilities and sweeps will be numbered. Only primary locations will have sequential numbers, all secondary locations will be alpha-numeric, the numeric number will match the number on the primary structure and will be sequential alpha characters after. See the attached drawing package for examples.
- i) The “Call before you dig” (811 or 1-800-424-5555) shall be up to date and contained on each sheet.

IV.) The Framing Layout will contain the following:

- a) Shall contain all framing for the electrical, street light, and fiber optic layouts.
- b) The electrical framing shall be first, followed by the street light framing and lastly the fiber optic framing. If possible, contain all framing within one sheet but if needed more sheets can be used.
- c) All secondary locations must be below the primary locations they are associated with.
- d) All overhead dip locations will be framed by Grant PUD's Engineering Technician. If the design is all overhead the Technician will assist and guide the Design Engineer in the correct framing.
- e) The framing shall designate the difference between owner/developer supplied and installed - Grant PUD supplied, owner/developer installed and Grant PUD supplied and installed.
- f) The "Call before you dig" (811 or 1-800-424-5555) shall be up to date and contained on each detail sheet.

V.) The Schedules Layout will contain the following:

- a) The electrical schedules shall be laid out as follows:
 - 6" Conduit, 3 Phase Primary (3-1100AL), 6" Sweeps
 - 4" Conduit, 3 Phase Primary (3-1/0AL-EPR), 4" Sweeps
 - 2" Conduit, 1 Phase Primary (1/0AL-EPR), 2" Sweeps
 - 3" Conduit, 1 Phase Secondary (350AL TX), 3" Sweeps
 - 2" Street Light Conduit, 1 Phase Secondary (2-#6AL), 2" Sweeps (or larger if needed)
 - 3 phase secondary as needed.
- b) The Fiber Optic schedules shall be laid out as follows:
 - 2" Conduit (Orange) w/ #12 THHN Wire, 2" Sweeps – (express)
 - 2" Conduit (Orange) w/ #12 THHN Wire, 2" Sweeps – (distribution)
- c) There is no need to designate Fiber Optic Cable unless directed otherwise by Grant PUD's Engineering Technician.
- d) The schedules shall designate the difference between Owner/Developer supplied and installed and Grant PUD supplied and installed.
- e) All schedules shall show the conductor make up as follows:
 - 20'+120'+20', this represents 20' out of the vault of transformer pad + the conduit length as shown on the drawings and in the conduit schedule + into the transformer vault or pad.
- f) For all make up lengths please reference the Standard Underground Conductor Make-Up Lengths, shown in the Electric System Design criteria above.

VI.) The Underground Schematic Layout will contain the following:

- a) North Arrow
- b) Road Names
- c) Dimensions from device to section corners or road intersections where applicable.
- d) All new cable tags, pad tags, vault tags and device's to be fused (as in the case of switchgear or DIP poles) shall be underlined to differentiate the new from the old. Especially important on combined schematics where the new meets the old.
- e) All existing underground electrical facilities where applicable.
- f) All proposed new primary underground facilities.
- g) Each cable run will include the cable size and length.

VII.) The Details Layout will contain the following:

- a) A north arrow on each detail where applicable.
- b) The following details shall be contained within each drawing package:
 - Typical trench construction (Can be modified to match design)
 - Typical Common Trench Detail
 - U46V / Pedestal – Section Detail
 - Typical Fiber Hand Hole/Transformer Moped/Street Light/Switch Vault Placement
 - Typical Fiber Vault/Transformer Moped/Street Light/Switch Vault Placement
 - Secondary Pedestal Detail
 - Typical groupings of all utility structures such as @ lot lines that contain electric, fiber, telephone, TV, & gas structures.
- c) The following details are optional but must be contained within the drawing package if the facilities are contained within the design.
 - Street Light Pole & Hand Hole Placement
 - Concrete Encased Conduit Construction
 - Sonet Tube Detail
- d) Typical Details can be altered to match the design.
- e) The notes contained within the sample drawing shall be on each detail page.
- f) The Conduit specifications contained within the sample drawing shall be on each detail page.
- g) The “Call before you dig” (811 or 1-800-424-5555) shall be up to date and contained on each detail sheet.

VIII.) The All Combined Layout will contain the following:

- a) North Arrow
- b) Legend
- c) Roads and Road Names
- d) Road Right of Way & Utility Easements
- e) Lot lines, with Lot and Block Numbers.
- f) All existing adjacent Overhead and Underground electrical and fiber optic facilities.
- g) All proposed new primary and secondary electrical facilities and all new fiber optic facilities.
- h) All new and existing adjacent infrastructure and utilities, including but not limited to, water pipe runs and water meters, sewer pipe runs and sewer services, storm drains and catch basins, Gas, Phone, TV and Cable.
- i) All civil infrastructure will be contained within one AutoCAD block.

Deliverables:

The Owner/Developer shall deliver to Grant PUD the following deliverables as required through-out the design and construction process:

Land Use Documents:

The Owner/Developer shall provide executed copies of any and all required agency developmental approvals to Grant PUD's Engineering Technician, i.e. approved preliminary plat, approved building site plan, etc., prior to the placement of any electrical facilities.

Preliminary Drawings:

Submit two (2) sets of preliminary hard copy drawings for mark-up and approval prior to the pre-construction meeting and approval of the construction drawings. At Grant PUD's Engineering Technician's discretion electronic CAD files via email may be acceptable.

"Approved for Construction" Drawings:

Furnish four (4) sets of Grant PUD approved drawings marked "Approved for Construction" and one electronic copy in an AutoCAD format to Grant PUD's Engineering Technician within two(2) weeks of final approval. The drawings shall contain Professional Engineer signed and stamped per RCW and WAC requirements.



























As-Built Drawings:

Upon completion of construction the Owner/Developer shall furnish Grant PUD a signed and stamped set of drawings marked "As-Built" with the date of construction completion and an electronic copy in an AutoCAD format for Grant PUD use.

SAMPLE DRAWINGS

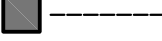
13 Drawings are provided (without page numbers). Pages 25 thru 37

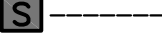

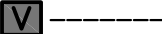









GCPUD AMFM LAYERS/BLOCKS

ITEM	NAME	LAYER NAME	LINE TYPE	PEN	SCREEN	BLOCK NAME	ATTRIBUTES
	15KV OVERHEAD	ED-CPOH-EXST-LIN	CONTINUOUS	7	WHITE	NONE	NONE
	15KV UNDERGROUND	ED-CPUG-EXST-LIN	DASHED2	7	WHITE	NONE	NONE
	600V OVERHEAD	ED-CSSO-EXST-LIN	CONTINUOUS	3	GREEN	NONE	NONE
	600V UNDERGROUND	ED-CSSU-EXST-LIN	UG_SEC	3	GREEN	NONE	NONE
	STREETLIGHT - OVERHEAD	ED-CSLO-EXST-LIN	CONTINUOUS	3	GREEN	NONE	NONE
	115/230KV OVERHEAD	ET-CPUD-EXST-LIN	CENTER	1	RED	NONE	NONE
	CANAL RIGHT OF WAY	SF-CANL-EXST-LIN	CANAL	180		NONE	NONE
	SHORELINE	SF-SHOR-EXST-LIN	CONTINUOUS	7	WHITE	NONE	NONE
	DRAINAGE RIGHT OF WAY	SV-DRRW-EXST-LIN	CANAL	180		NONE	NONE
	FENCE	SF-FENC-EXST-LIN	CONTINUOUS	7	WHITE	NONE	NONE
	COUNTY LINE	SV-CNTY-EXST-LIN	CONTINUOUS	7	WHITE	NONE	NONE
	RAILROAD	SF-RLRD-EXST-LIN	PHANTOM	4	CYAN	NONE	NONE
	EASEMENT	SV-ESMT-EXST-LIN	CANAL	180		NONE	NONE
	FARM UNIT	SV-FARM-EXST-LIN	CONTINUOUS	2	YELLOW	NONE	NONE
	LOT LINE	SV-LOTL-EXST-LIN	CONTINUOUS	2	YELLOW	NONE	NONE
	MEANDER LINE	SV-MEAN-EXST-LIN	CONTINUOUS	7	WHITE	NONE	NONE
	PROJECT LANDS	SV-PROJ-EXST-LIN	PHANTOM	7	WHITE	NONE	NONE
	ROAD RIGHT OF WAY	SV-RDRW-EXST-LIN	PHANTOM	4	CYAN	NONE	NONE
	SECTION LINE	SV-SECT-EXST-LIN	CONTINUOUS	2	YELLOW	NONE	NONE
	DEVICES	ED-DEVS-EXST-BLK	CONTINUOUS	6	MAGENTA	DEVICE	TYPE, DEVICE, RATING
	POLE	ED-PPOL-EXST-BLK	CONTINUOUS	7	WHITE	DWPOLE	OWNER, CABLETV, PHONE, OTHER, MATERIAL, TREATMENT YEAR, HEIGHT, CLASS, INSTALL YEAR, WO
	NEW POLE	ED-PPOL-PREL-BLK	CONTINUOUS	7	WHITE	DWPOLE	OWNER, CABLETV, PHONE, OTHER, MATERIAL, TREATMENT YEAR, HEIGHT, CLASS, INSTALL YEAR, WO
	TRANSFORMER BOX	ED-PADS-EXST-BLK	CONTINUOUS	7	WHITE	EXST_XMR	NONE
	NEW TRANSFORMER BOX	ED-PADS-FUTR-BLK	CONTINUOUS	7	WHITE	NEW_XMR	NONE
	SWITCHGEAR	ED-VAUL-EXST-BLK	CONTINUOUS	7	WHITE	EXST_SWGRVT	NONE
	NEW SWITCHGEAR	ED-VAUL-FUTR-BLK	CONTINUOUS	7	WHITE	NEW_SWRVT	NONE
	VAULT	ED-VAUL-EXST-BLK	CONTINUOUS	7	WHITE	EXST_SWVT	NONE
	NEW VAULT	ED-VAUL-FUTR-BLK	CONTINUOUS	7	WHITE	NEW_SWVT	NONE

GCPUD AMFM LAYERS/BLOCKS

ITEM	NAME	LAYER NAME	LINE TYPE	PEN	SCREEN	BLOCK NAME	ATTRIBUTES
	PVC CONDUIT	ED-DUCT-EXST-LIN	CONTINUOUS	2	YELLOW	DDUCTP	NONE
	METAL CONDUIT	ED-DUCT-EXST-LIN	CONTINUOUS	2	YELLOW	DDUCTP	NONE
	DOWN GUY	ED-GUYS-EXST-BLK	CONTINUOUS	6	MAGENTA	DGUY	NONE
	SIDEWALK GUY	ED-GUYS-EXST-BLK	CONTINUOUS	6	MAGENTA	DSGUY	NONE
	SPAN GUY	ED-GUYS-EXST-BLK	CONTINUOUS	6	MAGENTA	DSPAN	NONE
	DOUBLE SPAN GUY	ED-GUYS-EXST-BLK	CONTINUOUS	6	MAGENTA	DBGUY	NONE
	POLEMOUNT TRANSFORMER	ED-XMRS-EXST-BLK	CONTINUOUS	6	MAGENTA	XPOLMT	STENCIL, PHASE, BANK, POINT #, WO, TAP
	PADMOUNT TRANSFORMER	ED-XMRS-EXST-BLK	CONTINUOUS	6	MAGENTA	XPADMT	STENCIL, PHASE, BANK, POINT #, WO, TAP
	TRANCLOSURES *NOTE: NO LONGER USED FOR NEW DESIGN.	ED-XTRN-EXST-BLK	CONTINUOUS	6	MAGENTA	XTRNSCL	PHASE, STENCIL#, VOLTAGE, KVA
	DEVICE	ED-DEVS-EXST-BLK	CONTINUOUS	6	MAGENTA	DEVICE	TYPE, DEVICE, RATING A AIR SWITCH C CAPACITOR D DISCONNECT F FUSED CUTOUT O OIL SWITCH P POTHEAD PC PHOTO CONTROL RM RELAY, MULTIPLE RS RELAY, SERIES SC SWITCHED CAPACITOR SS SUN SWITCH X RECLOSER
	REGULATOR	ED-DEVS-EXST-BLK	CONTINUOUS	6	MAGENTA	DVREG	DEVICE TYPE, DDI #, RATING, STENCIL, PHASE
	HANDHOLE	ED-HHOL-EXST-BLK	CONTINUOUS	3	GREEN	DVHNDHO	NONE
	PEDESTAL	ED-PED-FUTR-BLK	CONTINUOUS	94		PED	NONE
	STREET LIGHT	ED-STLT-EXST-BLK	CONTINUOUS	6	MAGENTA	DSTLITE	AREA, NUMBER
	STREET LIGHT & HANDHOLE	ED-STLT-EXST-BLK	CONTINUOUS	6	MAGENTA	NEW_SLHH	NONE
	TRANSMISSION POLE	ET-POLE-EXST-BLK	CONTINUOUS	1	RED	TPOLE	# POLES, OWNER, CABLETV, PHONE, MATERIAL TREATMENT YEAR, HEIGHT, INSTALL YEAR, WO, ID#
	TRANSMISSION TOWER	ET-POLE-EXST-BLK	CONTINUOUS	1	RED	TTOWER	ED, CLASS, HEIGHT, TYPE, LINE NAME, DISTANCE TO, BEARING TO

GCPUD AMFM LAYERS/BLOCKS

ITEM	NAME	LAYER NAME	LINE TYPE	PEN	SCREEN	BLOCK NAME	ATTRIBUTES
	ELECTRONIC MARKER	ED-MARK-EXST-BLK	CONTINUOUS	7	WHITE	MARKER	NONE
	FIBER OVERHEAD	EF-CFOH-EXST-LIN	CONTINUOUS	30		NONE	NONE
	FIBER UNDERGROUND	EF-CFUG-EXST-LIN	CONTINUOUS	30		NONE	NONE
	FIBER OH CONDUIT	EF-CFOC-EXST-LIN	CONTINUOUS	30		NONE	NONE
	FIBER HUB	EF-FHUB-EXST-BLK	CONTINUOUS	30		FHUB	VAULTID
	FIBER HAND HOLE	EF-HHOL-EXST-BLK	CONTINUOUS	30		EXST_FHH	NONE
	NEW FIBER HAND HOLE	EF-HHOL-FUTR-BLK	CONTINUOUS	6	MAGENTA	NEW_FHH	NONE
	FIBER VAULT	EF-FVLT-EXST-BLK	CONTINUOUS	30		EXST_FVT	NONE
	NEW FIBER VAULT	EF-FVLT-FUTR-BLK	CONTINUOUS	6	MAGENTA	NEW_FVT	NONE
	FIBER LOOP	EF-LOOP-EXST-BLK	CONTINUOUS	30		FLOOP	ID
	FIBER SPLICE	EF-SPLC-EXST-BLK	CONTINUOUS	30		FSPLICE	ID
	SONETGEAR	EF-____-EXST-BLK	CONTINUOUS	30		F_____	ID

COMMON PUD PARTS & ASSEMBLYS

ITEM#	DESCRIPTION
FIBER	
J085	CONDUIT, SCH 40, FIBER OPTIC (ORANGE), 2"
J088	TRACER WIRE, #12 THHN ORG
J230	FIBER VAULT
JT02	CONDUIT, STEEL ELBOW GALV 2" 90 DEG
JT32	CONDUIT, SCH 40 ELBOW 2" 90 DEG
JU78	FIBER HANDHOLE
STREET LIGHTS	
L20	LIGHT 200W HPS 120V W/PC
LA12	12FT STEEL MAST ARM, STREET LIGHT
LDB30	LIGHT DIRECT BURIED, STEEL STANDARD, 30'
LDB40	LIGHT DIRECT BURIED, STEEL STANDARD, 40'
LF1	LIGHT FUSE, BREAK-AWAY SINGLE
LV	ENCLOSURE, LIGHTING JUNCTION BOX
LW	WIRE, CONDUIT, & ACCESORIES FOR LDB30-40, LPED30-40
UNDERGROUND FACILITIES	
U46V	VAULT, TRANSFORMER, 1 PHASE, 15-167KVA, 4'8" SQ. X 3'6"
U47V	VAULT, TRANSFORMER, 3 PHASE, 45-500KVA, 4'8" SQ. X 3'6"
U54V	VAULT, CONCRETE, SWITCHING, 1 PHASE, 4'8" SQ. X 5'6"
U55V	VAULT, CONCRETE, SWITCHING, 3 PHASE, 6' X 4' X 3'6"
U56SG	VAULT, CONCRETE, SWITCHGEAR, 9' X 5' X 7'2"
U56V	VAULT, CONCRETE, SWITCHING, 3 PHASE, 9' X 5' X 7'2"
U59	JUNCTION BUS, 4 POS
U69	CAP, PROTECTIVE GROUNDED
U79	PEDESTAL, SECONDARY - ABOVE GROUND
U84TEP	CONNECTOR, ELBOW, 1/0 AL EPR, 15KV LOADBREAK W/TEST POINT
UFIV03	FAULT INDICATOR UG TPR 300A 1P
UA9	CONCRETE GAURD POST
CONDUIT, ELBOWS & BELL ENDS	
T22	CONDUIT, SCH 40 PVC, 2"
T23	CONDUIT, SCH 40 PVC, 3"
T14	CONDUIT, SCH 40 PVC, 4"
T16	CONDUIT, SCH 40 PVC, 6"
T32	CONDUIT, SCH 40 PVC ELBOW DB 2" X 36"R, 90 DEG
T32A	CONDUIT, SCH 40 PVC ELBOW DB 2" X 24"R, 90 DEG
T33	CONDUIT, SCH 40 PVC ELBOW DB 3" X 36"R, 90 DEG
T33A	CONDUIT, SCH 40 PVC ELBOW DB 3" X 24"R, 90 DEG
T34	CONDUIT, SCH 40 PVC ELBOW DB 4" X 36"R, 90 DEG
T42	CONDUIT, SCH 40 PVC ELBOW DB 4" X 36"R, 45 DEG
T52	CONDUIT, STEEL ELBOW GALV 2" X 36"R, 45 DEG
T53	CONDUIT, STEEL ELBOW GALV 3" X 36"R, 45 DEG
T54	CONDUIT, STEEL ELBOW GALV 4" X 36"R, 45 DEG
T56	CONDUIT, STEEL ELBOW GALV 6" X 36"R, 45 DEG
T62	CONDUIT, STEEL ELBOW GALV 2" X 36"R, 90 DEG
T63	CONDUIT, STEEL ELBOW GALV 3" X 36"R, 90 DEG
T64	CONDUIT, STEEL ELBOW GALV 4" X 36"R, 90 DEG
T66	CONDUIT, STEEL ELBOW GALV 6" X 36"R, 90 DEG
T92	CONDUIT, FIBERGLASS ELBOW 2" X 36"R, 90 DEG
T93	CONDUIT, FIBERGLASS ELBOW 3" X 36"R, 90 DEG
T94	CONDUIT, FIBERGLASS ELBOW 4" X 36"R, 90 DEG
T96	CONDUIT, FIBERGLASS ELBOW 6" X 36"R, 90 DEG
T80	SEALANT, INSTAFOAM, 1 CU. FT. KIT
T82	BELL END, 2" PVC
T83	BELL END, 3" PVC
T84	BELL END, 4" PVC
T86	BELL END, 6" PVC
CONDUCTORS	
A10C	600V UG SNGL #6 AL
A36C	600V UG TRIPLEX AL, 2 - 350 & 1-4/0
A01C1E	1/0 AL EPR 15KV, 1 PHASE
A01C3E	1/0 AL EPR 15KV, 3 PHASE
A05C3E	750 AL EPR 15KV, 3 PHASE
A08C3E	1100 AL EPR 15KV, 3PHASE

SEE GRANT PUD PARTS CATALOG FOR ITEMS NOT LISTED ABOVE.

DEVELOPMENT NAME

T.00N R.00E S.00

INCLUDE A VICINITY MAP OF THE AREA AROUND THE PLAT IN A 1/2 MILE RADIUS. INCLUDE THE CITY OR OUTLYING AREA NAME, ALL MAJOR STREET NAMES AND ANY ARTERIAL STREETS ADJACENT TO THE PLAT, A NORTH ARROW, ANY SURROUNDING PLAT NAMES. VICINITY MAP MAY NEED TO BE ENLARGED DEPENDING ON THE AREA THE PLAT IS LOCATED. THIS DECISION IS AT THE DISCRETION OF THE DESIGNER.



VICINITY MAP
NOT TO SCALE

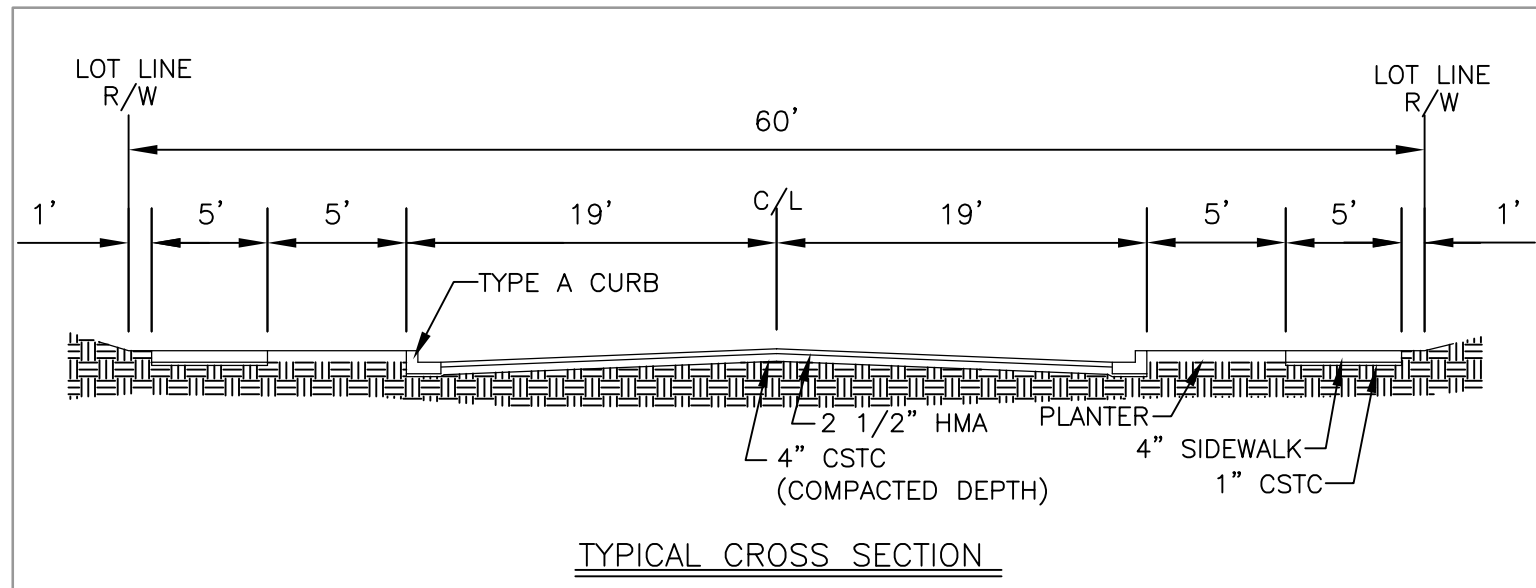

TYPICAL CROSS SECTION

CALL BEFORE YOU DIG 48 HOURS IN ADVANCE
DIAL 811 OR (1-800-424-5555)

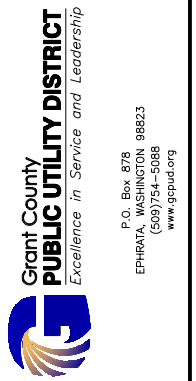

REV.	DESCRIPTION	DATE
3		
2		
1		
A0	PRELIMINARY New Drawing	

SHEET INDEX

- SHEET 1 COVER SHEET
- SHEET 2 PRIMARY CONDUIT LAYOUT
- SHEET 3 FIBER CONDUIT LAYOUT
- SHEET 4 FRAMING
- SHEET 5 SCHEDULES
- SHEET 6 SCHEMATIC
- SHEET 7 DETAIL SHT. 1
- SHEET 8 DETAIL SHT. 2
- SHEET 9 DETAIL SHT. 3
- SHEET 10 ALL FACILITIES COMBINED

YELLOW BOOK
EXHIBIT DRAWING
VICINITY MAP

DATE	BY	CHECKED	DATE	BY
07/25/09				
07/25/09				
07/25/09				

PRELIMINARY
CATEGORY: EXHIBIT-DWG
DRAWING NUMBER: MAB TCY 04/07/09 1 TO 10
EXHIBIT-DWG

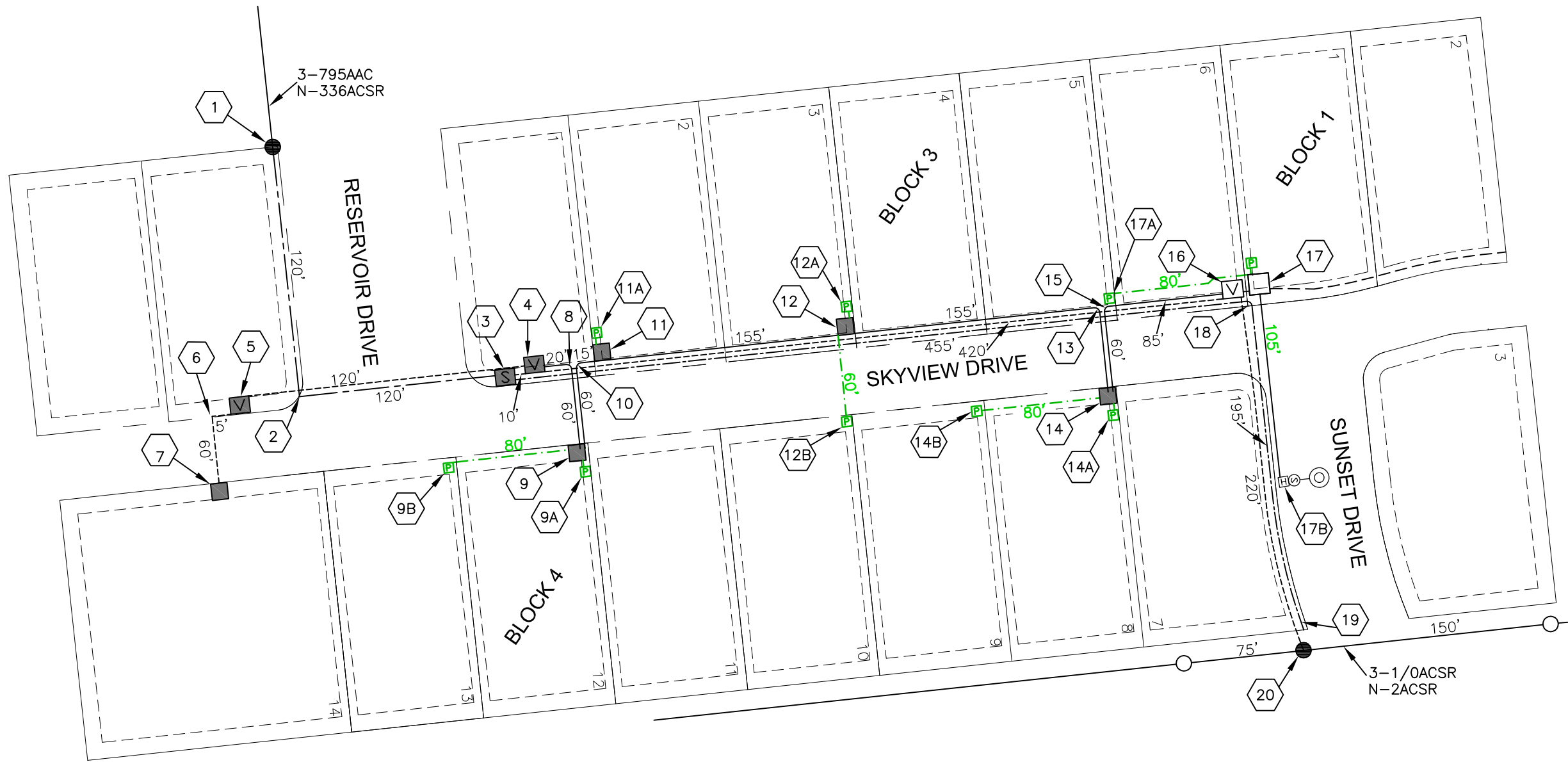

LEGEND

- EXISTING POLE
- NEW POLE
- ▣ NEW SWITCH VAULT
- ▣ EXISTING SWITCH VAULT
- ▣ NEW SWITCHGEAR VAULT
- ▣ EXISTING SWITCHGEAR VAULT
- ▣ NEW TRANSFORMER
- ▣ EXISTING TRANSFORMER
- ▣ PEDESTAL
- ⊙ NEW STREET LIGHT & HAND HOLE

- RIGHT OF WAY
- PROPERTY LINE
- - - PUBLIC UTILITY EASEMENT
- 2" SCH40 PVC CONDUIT
- - - 3" SCH40 PVC CONDUIT
- - - 4" SCH40 PVC CONDUIT
- - - 6" SCH40 PVC CONDUIT
- EXST. 1-PHASE POWER (IN CONDUIT)
- EXST. 3-PHASE POWER (IN CONDUIT)

CALL BEFORE YOU DIG 48 HOURS IN ADVANCE
DIAL 811 OR (1-800-424-5555)

 Grant County PUBLIC UTILITY DISTRICT <i>Excellence in Service and Leadership</i>		P.O. Box 878 EPHRATA, WASHINGTON 98823 (509)754-5088 www.gcpud.org					
REV.	DESCRIPTION	DSH	CHK	ORG	APP1	APP2	DATE
3							
2							
1							
A0	PRELIMINARY New Drawing						
YELLOW BOOK EXHIBIT DRAWING ELECTRICAL LAYOUT							
PRELIMINARY		SUB-CATEGORY		DATE FILED		PLOT DATE	
CATEGORY		SUB-CATEGORY		DATE FILED		PLOT DATE	
EXHIBIT-DWG		EXHIBIT-DWG		06/25/09		06/25/09	
DESIGNER		CHECKER		DATE		SCALE	
MAB		TCY		04/07/09		10	
DRAWING NUMBER		DRAWING NUMBER		DRAWING NUMBER		DRAWING NUMBER	
EXHIBIT-DWG		EXHIBIT-DWG		EXHIBIT-DWG		EXHIBIT-DWG	

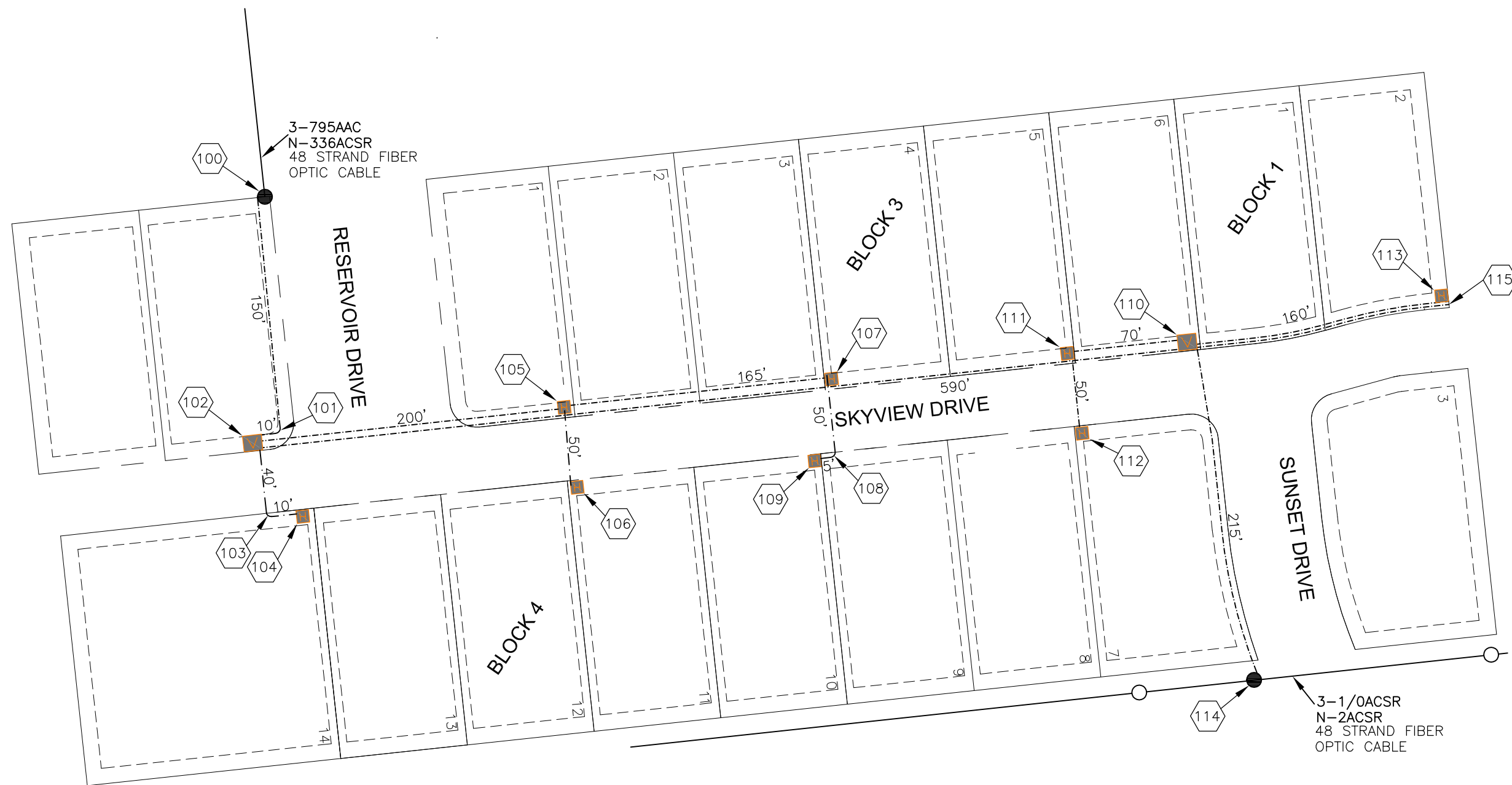

CALL BEFORE YOU DIG 48 HOURS IN ADVANCE
 DIAL 811 OR (1-800-424-5555)

- LEGEND**
- EXISTING POLE
 - NEW POLE
 - NEW FIBER VAULT
 - NEW FIBER HANDHOLE
 - ▣ EXISTING FIBER VAULT
 - ▣ EXISTING FIBER HANDHOLE
-
- RIGHT OF WAY
 - PROPERTY LINE
 - - - - PUBLIC UTILITY EASEMENT
 - - - - 2" SCH40 PVC ORANGE CONDUIT



Grant County PUBLIC UTILITY DISTRICT
Excellence in Service and Leadership

P.O. Box 878
 EPHRATA, WASHINGTON 98823
 (509)754-5088
 www.gcpud.org

REV.	DESCRIPTION	DSH	CHK	ORG.	APP1	APP2	DATE
3							
2							
1							
A0	PRELIMINARY New Drawing						

YELLOW BOOK
 EXHIBIT DRAWING
 FIBER LAYOUT

CATEGORY	SUB-CATEGORY	DATE	PLOT DATE	DRAWING SCALE
PRELIMINARY		06/25/09		B
DWG FILE: EXHIBIT-DWG	DATE: 06/25/09	DATE: 06/25/09	DATE: 06/25/09	DATE: 06/25/09
DESIGNER: MAB	CHECKER: TCY	DATE: 06/07/09	DATE: 06/07/09	DATE: 06/07/09
DRAWING NUMBER				

EXHIBIT-DWG

ELECTRICAL FRAMING

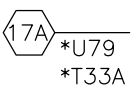
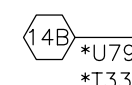
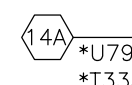
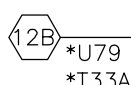
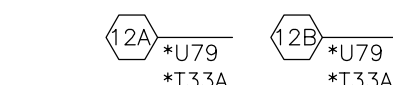
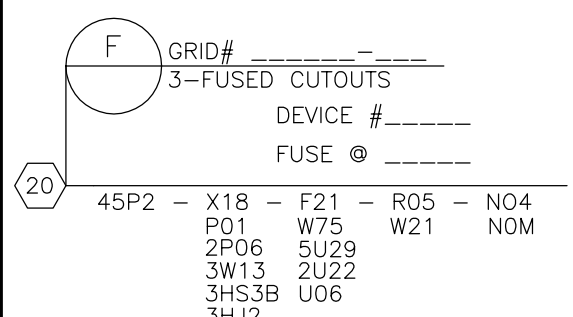
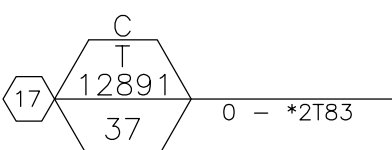
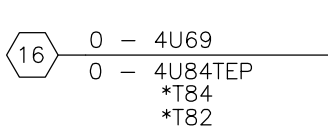
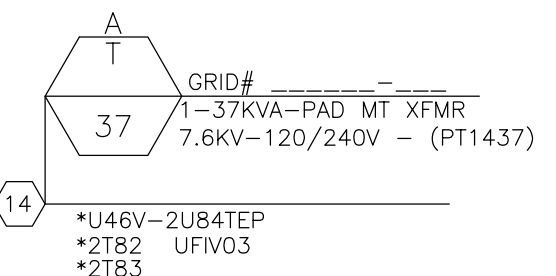
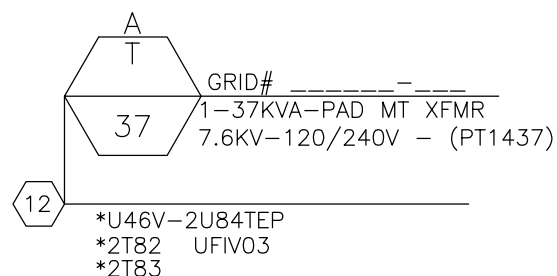
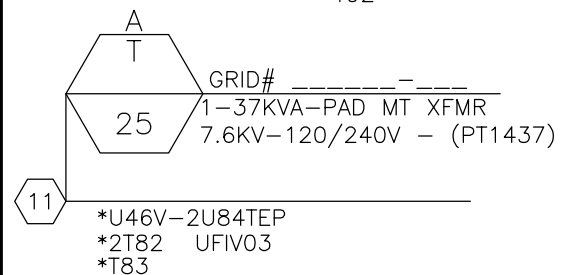
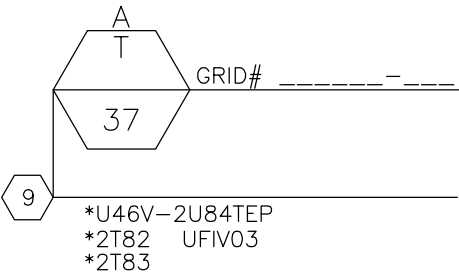
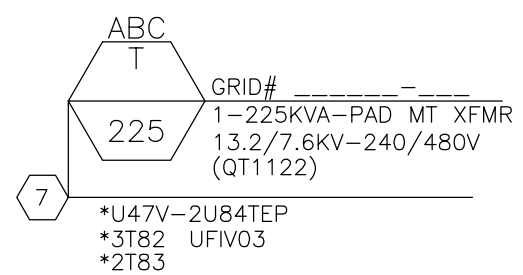
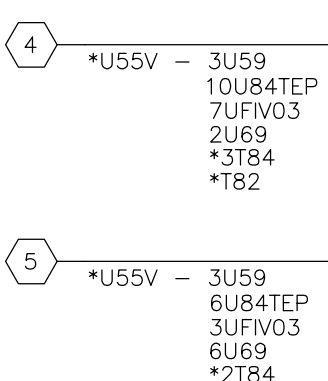
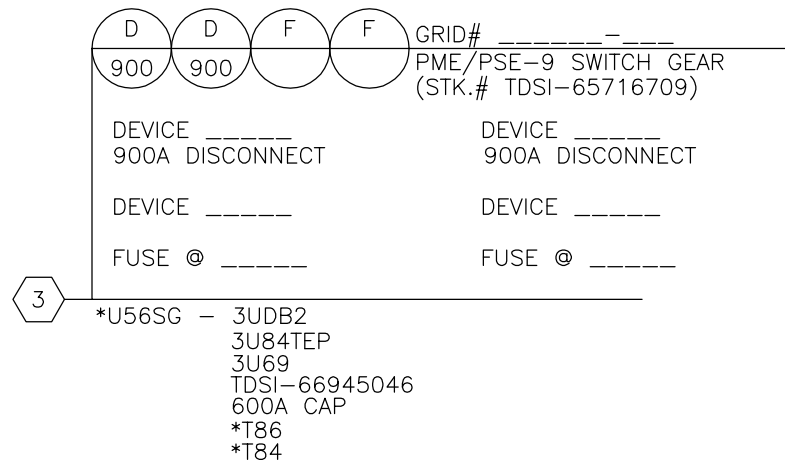
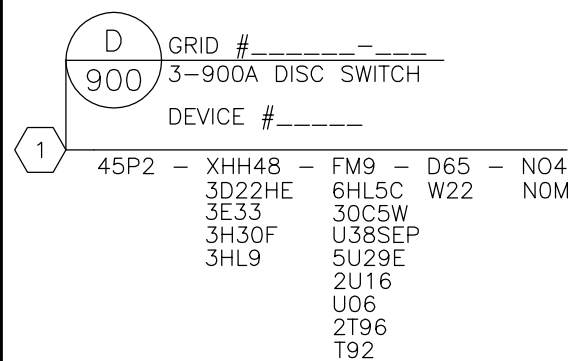

STREET LIGHTS

FIBER FRAMING

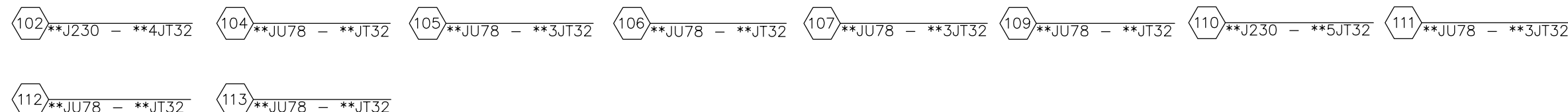

DISTRICT PROVIDED AND INSTALLED.
 * SUPPLIED & INSTALLED BY THE DEVELOPER.
 ** DEVELOPER PROVIDED, DEVELOPER INSTALLED.

CALL BEFORE YOU DIG 48 HOURS IN ADVANCE
 DIAL 811 OR (1-800-424-5555)

**Grant County
PUBLIC UTILITY DISTRICT**
 Excellence in Service and Leadership

P.O. Box 878
 EPHRATA, WASHINGTON 99823
 (509)754-5088
 www.gcpud.org

REV.	DESCRIPTION	DATE
3		
2		
1		
A0	PRELIMINARY New Drawing	

YELLOW BOOK
EXHIBIT DRAWING
FRAMING DRAWING

TITLE

CATEGORY	SUB-CATEGORY	DATE	PLOT DATE	PLOT BKT
EXHIBIT-DWG		07/25/09		
DESIGNER	DRAWN	CHECKED	SCALE	DWG. SIZE
MAB	TCY	TCY	4:10	B
DRAWING NUMBER				

EXHIBIT-DWG

ELECTRICAL SCHEDULES

6" CONDUIT SCHEDULE CUSTOMER PROVIDED & INSTALLED			
LOC	LOC	DESCRIPTION	DISTANCE
1	3	2-6" SCH 40 PVC	240'
3	19	2-6" SCH 40 PVC	650'
TOTAL 6" SCH 40 PVC CONDUIT			990'x2=1880'

3 PHASE PRIMARY CONDUCTOR SCHEDULE PUD PROVIDED & INSTALLED			
LOC	LOC	DESCRIPTION	DISTANCE
1	3	3-110AL-15KV (A08C3E)	45'+240'+20'=305'
3-110AL-15KV (A08C3E)			TOTAL = 305'

6" SWEEP SCHEDULE CUSTOMER PROVIDED & INSTALLED		
LOC	DESCRIPTION	QTY
2,18	6" FIBERGLASS-36" RAD-90°	2
TOTAL 6" FIBERGLASS-36" RAD-90°		4

3" SECONDARY CONDUIT SCHEDULE CUSTOMER PROVIDED & INSTALLED			
LOC	LOC	DESCRIPTION	DISTANCE
9	9A	3" SCH 40 PVC CONDUIT	3'
9	9B	3" SCH 40 PVC CONDUIT	80'
11	11A	3" SCH 40 PVC CONDUIT	3'
12	12A	3" SCH 40 PVC CONDUIT	3'
12	12B	3" SCH 40 PVC CONDUIT	60'
14	14A	3" SCH 40 PVC CONDUIT	3'
14	14B	3" SCH 40 PVC CONDUIT	80'
17	17A	3" SCH 40 PVC CONDUIT	80'
TOTAL 3" SCH 40 PVC CONDUIT			312'

4" CONDUIT SCHEDULE CUSTOMER PROVIDED & INSTALLED			
LOC	LOC	DESCRIPTION	DISTANCE
3	4	4" SCH 40 PVC	10'
4	5	4" SCH 40 PVC	120'
5	7	4" SCH 40 PVC	65'
4	16	4" SCH 40 PVC	420'
16	20	4" SCH 40 PVC	220'
TOTAL 4" SCH 40 CONDUIT			835'

3 PHASE PRIMARY CONDUCTOR SCHEDULE PUD PROVIDED & INSTALLED			
LOC	LOC	DESCRIPTION	DISTANCE
3	4	3-1/OAL-EPR-15KV (A01C3E)	20+10'+20'=50'
4	5	3-1/OAL-EPR-15KV (A01C3E)	20+120'+20'=160'
5	7	3-1/OAL-EPR-15KV (A01C3E)	20+65'+20'=105'
4	16	3-1/OAL-EPR-15KV (A01C3E)	20+420'+20'=460'
16	20	3-1/OAL-EPR-15KV (A01C3E)	20+220'+45'=285'
3-1/OAL-EPR-15KV (A01C3E)			TOTAL=1,060'

4" SWEEP SCHEDULE CUSTOMER PROVIDED & INSTALLED		
LOC	DESCRIPTION	QTY
6	4" FIBERGLASS-36" RAD-90°	1
TOTAL 4" FIBERGLASS-36" RAD-90°		1

2" PRIMARY CONDUIT SCHEDULE CUSTOMER PROVIDED & INSTALLED			
LOC	LOC	DESCRIPTION	DISTANCE
4	9	2" SCH 40 PVC	80'
9	11	2" SCH 40 PVC	75'
11	12	2" SCH 40 PVC	155'
12	14	2" SCH 40 PVC	215'
14	16	2" SCH 40 PVC	145'
TOTAL 2" SCH 40 PVC CONDUIT			670'

SINGLE PHASE PRIMARY CONDUCTOR SCHEDULE PUD PROVIDED & INSTALLED			
LOC	LOC	DESCRIPTION	DISTANCE
4	9	1/OAL-EPR-15KV (A01C1E)	20'+80'+5'=105'
9	11	1/OAL-EPR-15KV (A01C1E)	5'+75'+5'=85'
11	12	1/OAL-EPR-15KV (A01C1E)	5'+155'+5'=165'
12	14	1/OAL-EPR-15KV (A01C1E)	5'+215'+5'=225'
14	16	1/OAL-EPR-15KV (A01C1E)	5'+145'+20'=130'
1/OAL-EPR-15KV (A01C1E)			TOTAL = 710'

2" SWEEP SCHEDULE CUSTOMER PROVIDED & INSTALLED		
LOC	DESCRIPTION	QTY
8,10,13,15	2" FIBERGLASS-36" RAD-90°	4
TOTAL 2" FIBERGLASS-36" RAD-90°		4

SECONDARY CONDUCTOR SCHEDULE CONTINUED			
LOC	LOC	DESCRIPTION	DISTANCE
9	9A	350 AL TX UG (A36C)	5'+3'+5'=13'
9	9B	350 AL TX UG (A36C)	5'+80'+5'=90'
11	11A	350 AL TX UG (A36C)	5'+3'+5'=13'
12	12A	350 AL TX UG (A36C)	5'+3'+5'=13'
12	12B	350 AL TX UG (A36C)	5'+60'+5'=70'
14	14A	350 AL TX UG (A36C)	5'+3'+5'=13'
14	14B	350 AL TX UG (A36C)	5'+80'+5'=90'
17	17A	350 AL TX UG (A36C)	5'+80'+5'=90'
TOTAL 350 AL TX UG (A36C)			392'

2" STREET LIGHT CONDUIT SCHEDULE CUSTOMER PROVIDED & INSTALLED			
LOC	LOC	DESCRIPTION	DISTANCE
17	17B	2" SCH 40 PVC CONDUIT	105'
TOTAL 2" SCH 40 PVC CONDUIT			105'

STREET LIGHT CONDUCTOR SCHEDULE PUD PROVIDED & INSTALLED			
LOC	LOC	DESCRIPTION	DISTANCE
17	17B	3 - #2 AL (A30C)	5'+105'+40'=150'
#2 AL (A30C)			TOTAL = 300'

FIBER SCHEDULES

2" FI. OP. (ORANGE) CONDUIT SCHEDULE CUSTOMER PROVIDED & INSTALLED			
LOC	LOC	DESCRIPTION	DISTANCE
100	102	2" SCH 40 PVC W/#12 THH WIRE	160'
102	104	2" SCH 40 PVC W/#12 THH WIRE	50'
102	105	2" SCH 40 PVC W/#12 THH WIRE	200'
105	106	2" SCH 40 PVC W/#12 THH WIRE	50'
105	107	2" SCH 40 PVC W/#12 THH WIRE	165'
107	108	2" SCH 40 PVC W/#12 THH WIRE	55'
107	111	2" SCH 40 PVC W/#12 THH WIRE	145'
102	110	2" SCH 40 PVC W/#12 THH WIRE	590'
110	111	2" SCH 40 PVC W/#12 THH WIRE	70'
111	112	2" SCH 40 PVC W/#12 THH WIRE	50'
110	113	2" SCH 40 PVC W/#12 THH WIRE	160'
110	114	2" SCH 40 PVC W/#12 THH WIRE	215'
110	115	2" SCH 40 PVC W/#12 THH WIRE	160'
TOTAL 2" SCH 40 PVC (ORANGE)(J085)			2,070'
TOTAL #12 THH TRACER WIRE (J088)			2,350'

2" FI. OP. (ORANGE) CONDUIT SWEEP SCHEDULE CUSTOMER PROVIDED & INSTALLED		
LOC	DESCRIPTION	QTY
101,103,108	2" SCH 40 PVC-36" RAD-90°	1
TOTAL 2" SCH 40 PVC SWEEPS-36" RAD-90°		3

SEE FRAMING SHEET FOR OTHER
SWEEP LOCATIONS (JT32)

CALL BEFORE YOU DIG 48 HOURS IN ADVANCE
DIAL 811 OR (1-800-424-5555)

Grant County
PUBLIC UTILITY DISTRICT
Excellence in Service and Leadership

P.O. Box 878
EPHRATA, WASHINGTON 98823
(509)754-5088
www.gcpud.org

DATE					
APP1	APP2	APP3	APP4	APP5	APP6

DATE					
APP1	APP2	APP3	APP4	APP5	APP6

DATE					
APP1	APP2	APP3	APP4	APP5	APP6

DATE					
APP1	APP2	APP3	APP4	APP5	APP6

DATE					
APP1	APP2	APP3	APP4	APP5	APP6

DATE					
APP1	APP2	APP3	APP4	APP5	APP6

DATE					
APP1	APP2	APP3	APP4	APP5	APP6

DATE					
APP1	APP2	APP3	APP4	APP5	APP6

DATE					
APP1	APP2	APP3	APP4	APP5	APP6

DATE					
APP1	APP2	APP3	APP4	APP5	APP6

DATE					
APP1	APP2	APP3	APP4	APP5	APP6

DATE					
APP1	APP2	APP3	APP4	APP5	APP6

DATE					
APP1	APP2	APP3	APP4	APP5	APP6

DATE					
APP1	APP2	APP3	APP4	APP5	APP6

DATE					
APP1	APP2	APP3	APP4	APP5	APP6

DATE					
APP1	APP2	APP3	APP4	APP5	APP6

DATE					
APP1	APP2	APP3	APP4	APP5	APP6

DATE					
APP1	APP2	APP3	APP4	APP5	APP6

DATE					
APP1	APP2	APP3	APP4	APP5	APP6

DATE					
APP1	APP2	APP3	APP4	APP5	APP6

DATE					
APP1	APP2	APP3	APP4	APP5	APP6

DATE					
APP1	APP2	APP3	APP4	APP5	APP6

DATE					
APP1	APP2	APP3	APP4	APP5	APP6

DATE					
APP1	APP2	APP3	APP4	APP5	APP6

DATE					
APP1	APP2	APP3	APP4	APP5	APP6

DATE					
APP1	APP2	APP3	APP4	APP5	APP6

DATE					
APP1	APP2	APP3	APP4	APP5	APP6

DATE					
APP1	APP2	APP3	APP4	APP5	APP6

DATE					
APP1	APP2	APP3	APP4	APP5	APP6

DATE					
APP1	APP2	APP3	APP4	APP5	APP6

DATE					
APP1	APP2	APP3	APP4	APP5	APP6

DATE					
APP1	APP2	APP3	APP4	APP5	APP6

DATE					
APP1	APP2	APP3	APP4	APP5	APP6

DATE					
APP1	APP2	APP3	APP4	APP5	APP6

DATE				
------	--	--	--	--

Prototype Drawings:

1PHASE
3PHASE
UGSCHEMB
UGSCHEMD

Use ortho mode when applicable. Schematic blocks are designed to be used with SNAP set to .05 x drawing scale. Make sure converging lines meet. Use District's blocks, linetypes, layers. Do not create any new entities. Use example for text styles and heights. All dimensions are from edge of vault to edge of vault, not conductor lengths. Purge the drawing when finished, zoom extents and plot to .dwf.

All text height is 0.125, style ROMANS unless noted.

County Road Names:
"K" S.E. - No road exists.
CO. RD. "K" S.E. - Road exists.

Dimension to section corners where applicable.

Layers

Text - UGTEXT
Conductor - A, B or C
Blocks - UGSCHEM
DDI Numbers - DDINUMBER
Multiple numbers in lower right
WOs - WOHISTRY
Normal Opens - OPEN-TXT

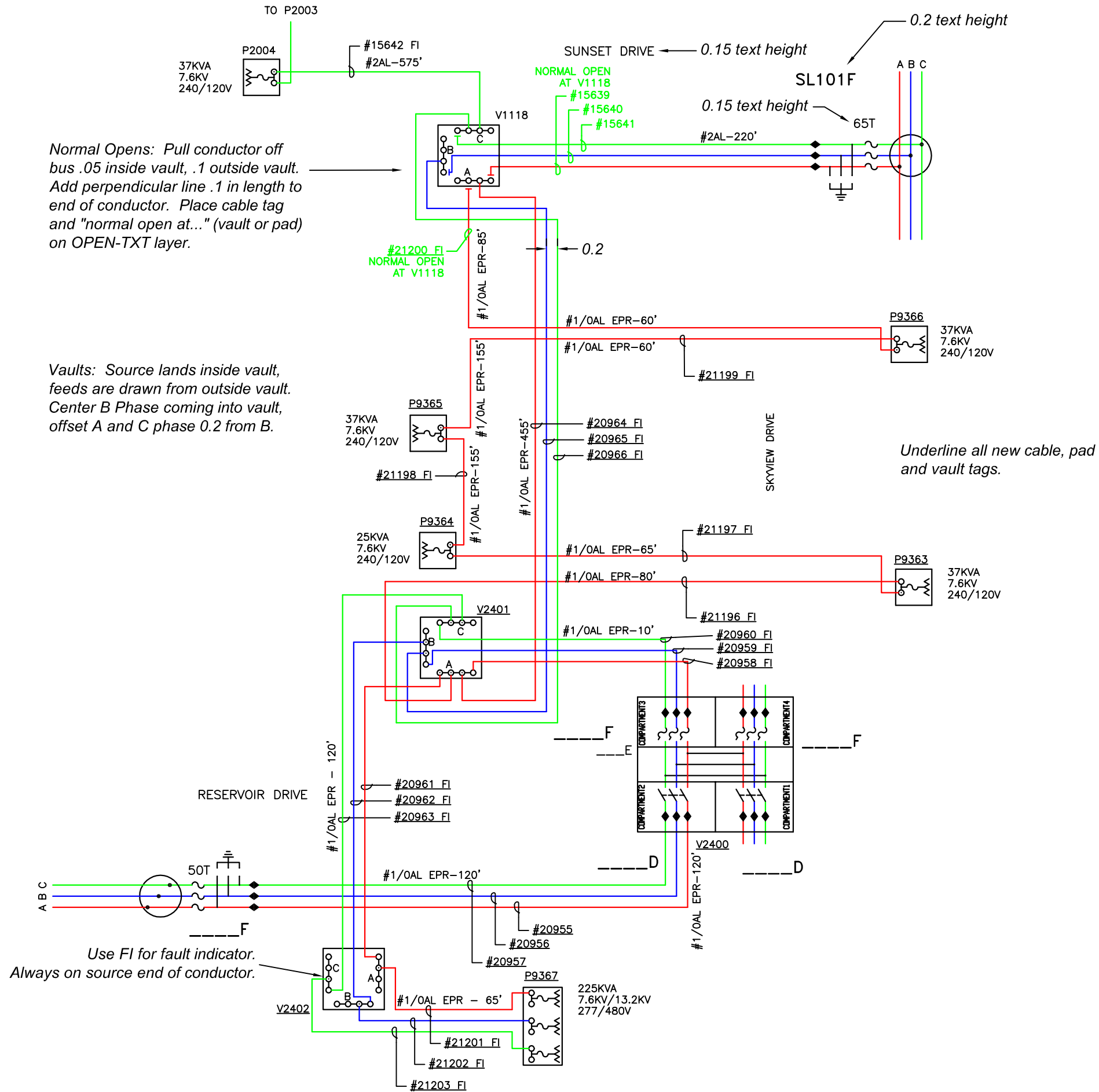

Use FI for fault indicator.
Always on source end of conductor.

Normal Opens: Pull conductor off bus .05 inside vault, .1 outside vault. Add perpendicular line .1 in length to end of conductor. Place cable tag and "normal open at..." (vault or pad) on OPEN-TXT layer.

Vaults: Source lands inside vault, feeds are drawn from outside vault. Center B Phase coming into vault, offset A and C phase 0.2 from B.

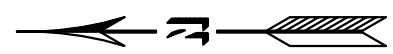

0.2 text height style - romand
SL101
SL102
SL103
SL104

If schematic has more than one device, list all devices on layer DDINUMBER. Do not include device type extension.

		P.O. Box 878 Ephrata, Washington 98823 (509)754-5088 www.gcpud.org	
DATE		DATE	
APP1 APP2		APP1 APP2	
CHK		CHK	
DSN		DSN	
DESCRIPTION		DESCRIPTION	
REV.	3	REV.	1
	2		2
	1		3
	A0		A0
PRELIMINARY SUB-CATEGORY		PRELIMINARY New Drawing	
YELLOW BOOK EXHIBIT DRAWING UNDERGROUND SCHEMATIC			
CATEGORY PRELIMINARY	SUB-CATEGORY EXHIBIT-DWG	LAST FILE 06/25/09	PLOT BY SMA
DESIGNER SMA	CHECKER TCY	DATE 06/24/09	SHEET OF 6 10
DRAWING NUMBER EXHIBIT-DWG	DWG SIZE D		

TYPICAL TRENCH CONSTRUCTION

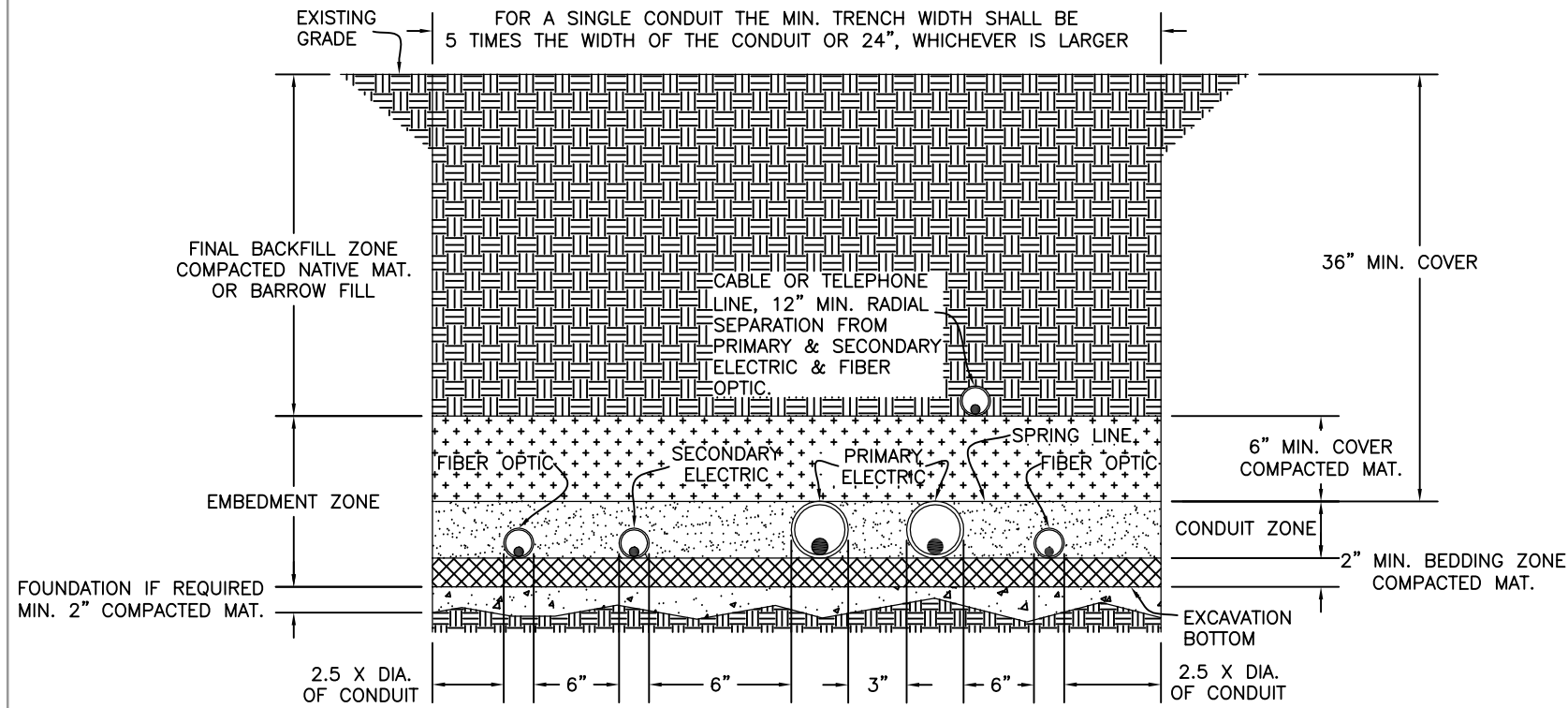

MULTI-CONDUITS SHALL BE CONFIGURED AS SHOWN.

NOTE:
ALL TRENCHING, TRENCH LOCATION IN REFERENCE TO OTHER UTILITIES, CONDUIT LOCATION WITHIN THE TRENCH, BACKFILL AND COMPACTION OF BACKFILL SHALL BE IN ACCORDANCE WITH ASTM INTERNATIONAL STANDARDS.

NOT TO SCALE

CONCRETE ENCASED CONSTRUCTION

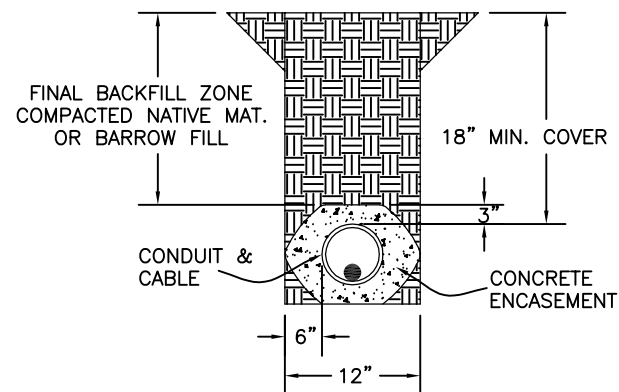

NOTE:
THIS METHOD OF REDUCED CLEARANCES IS ONLY ACCEPTABLE WITH PRIOR APPROVAL OF DISTRICT STAFF. CONDUIT SHALL REST ON EITHER CONCRETE OR SUITABLE FOUNDATION. CONCRETE ENCASEMENT SHALL BE A FOUR SACK MIX.

NOT TO SCALE

NOTES:

1. CUSTOMER TO PROVIDE ALL TRENCH, BACKFILL, CONDUIT, BEDDING, CONCRETE TRANSFORMER VAULTS, SWITCHING VAULTS, MOPEDS AND HAND HOLES TO GRANT COUNTY PUD SPECIFICATIONS.
2. INSTALL CAP AT END OF SPARE CONDUITS.
3. COORDINATE CONSTRUCTION WITH AREA LINE FOREMAN PHONE:
4. DEVELOPER TO PROVIDE ALL LOT CORNERS AND GRADE STAKES FOR CONSTRUCTION AND STAKING OF BURIED POWER LINES.
5. ALL SWITCHING VAULTS, TRANSFORMER VAULTS, AND HAND HOLES ARE TO BE INSTALLED AT FINAL GRADE PER GRANT COUNTY P.U.D. STANDARDS.
6. DEVELOPER TO COORDINATE WITH OTHER UTILITIES.
7. WARNING TAPE TO BE INSTALLED IN ALL TRENCHES 12"-16" ABOVE THE CONDUIT.
8. WARNING TAPE TO BE INSTALLED OVER ALL CONDUITS EXPOSED ABOVE FINAL GRADE.
9. P.U.D. MUST INSPECT AND APPROVE ALL CONDUITS AND VAULTS BEFORE BACKFILL.
10. OBTAIN FIBER OPTIC CONDUIT, VAULTS, HAND HOLES, AND INSTALL PER GRANT COUNTY P.U.D. STANDARDS.

CALL BEFORE YOU DIG 48 HOURS IN ADVANCE
DIAL 811 OR (1-800-424-5555)

TYPICAL COMMON TRENCH DETAIL

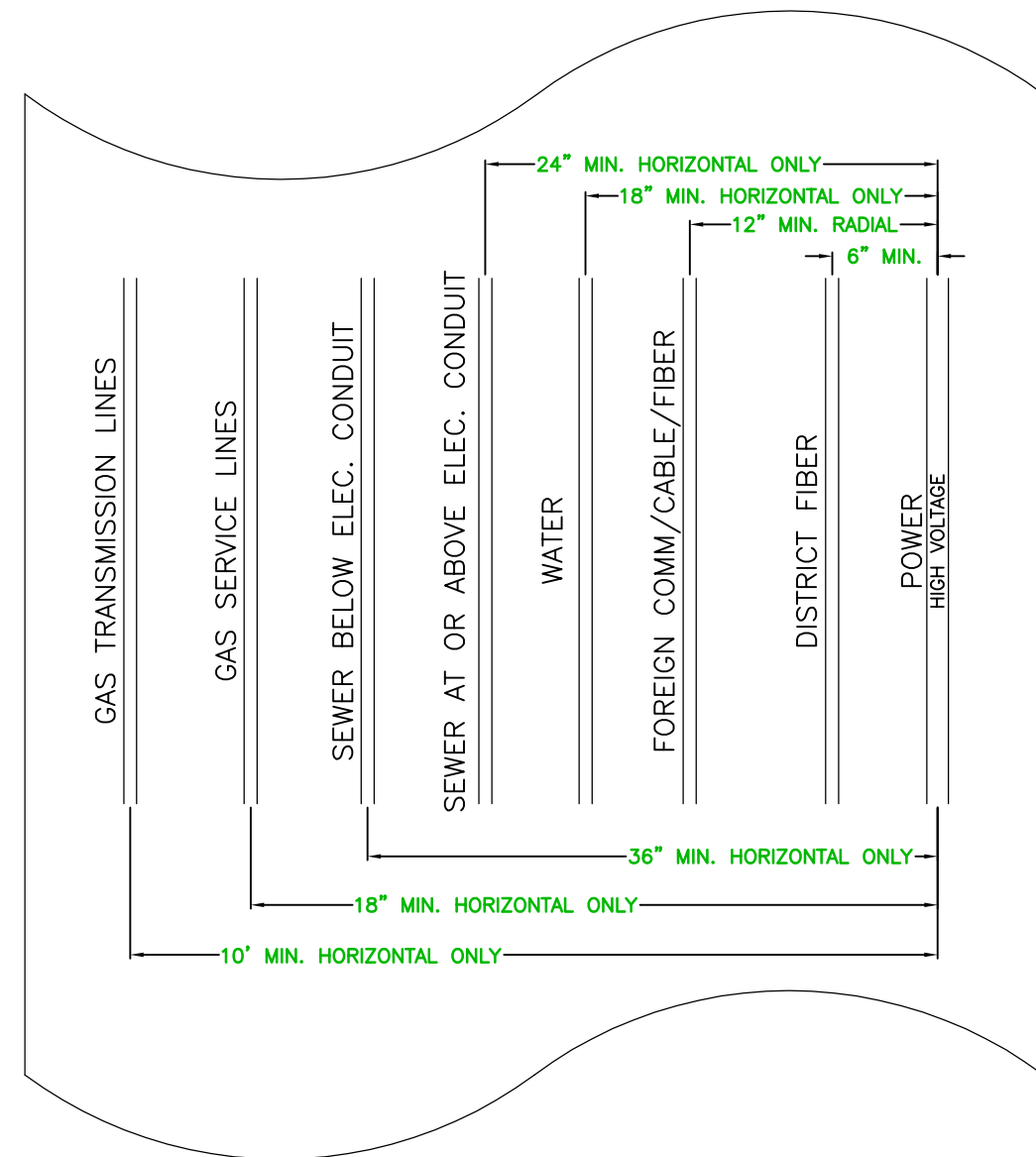

NOTE:
LOW VOLTAGE 120/240V REQUIRES 12" RADIAL SEPARATION FOR TELEPHONE OR TELEVISION-CABLE, 6" FOR DISTRICT FIBER, AND 12" FOR FOREIGN FIBER.

NOT TO SCALE

CONDUIT SPECIFICATIONS:

1. CONDUITS TO BE CENTERED AND ALIGNED TO PULL POWER CABLES DIRECTLY THROUGH KNOCKOUT ACCESS OPENING OF THE TRANSFORMER VAULT OR SWITCHING VAULT @ APPROXIMATELY 4" ABOVE INSIDE GRADE. PRIMARY CONDUITS SHALL ENTER AND EXIT @ OPPOSITE CORNERS OF VAULTS.
2. ALL MEDIUM HIGH VOLTAGE 36" RADIUS SWEEPS MUST BE MODIFIED TO EXTEND JUST ABOVE INSIDE GRADE @ TRANSFORMER VAULT OR SWITCH VAULT LOCATIONS.
3. USE FIBERGLASS OR GALV. STEEL SWEEPS FOR ALL PRIMARY CONDUIT.

REV.	DESCRIPTION	DATE
3		
2		
1		
A0	PRELIMINARY New Drawing	

YELLOW BOOK
EXHIBIT DRAWING
DETAIL LAYOUT 1

CATEGORY	SUB-CATEGORY	DATE FILED	DATE PLOTTED
PRELIMINARY	EXHIBIT-DWG	07/25/09	
MAB	TCY	07/07/09	10

EXHIBIT-DWG

PEDESTAL CONSTRUCTION DETAIL

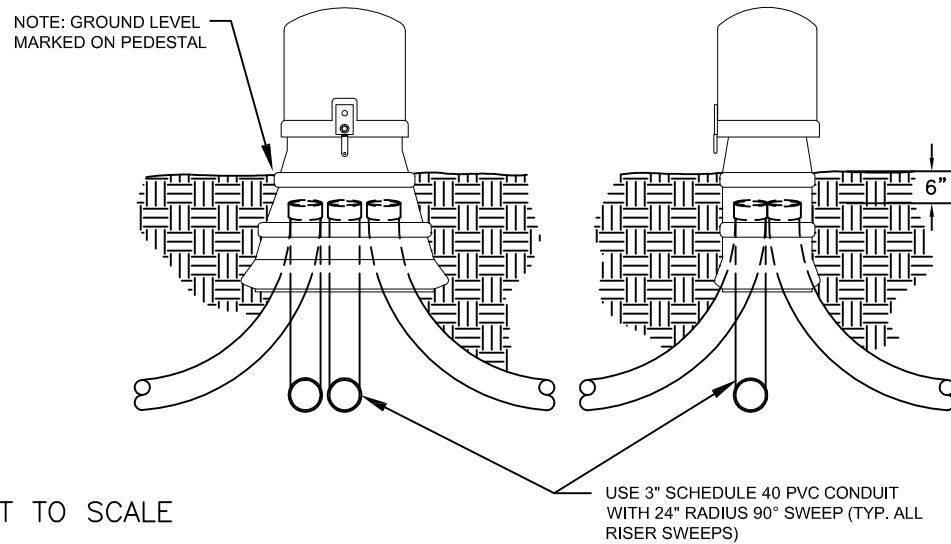
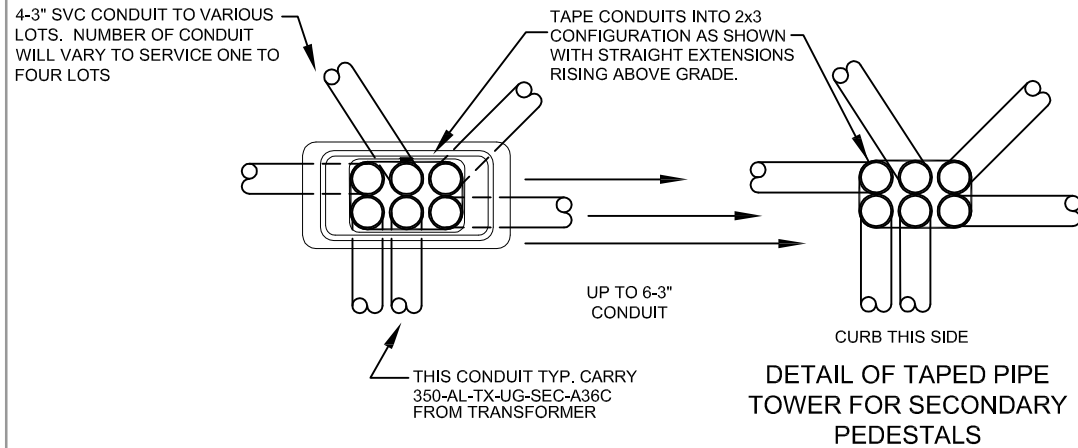

NOT TO SCALE

FIBER HANDHOLE CONSTRUCTION DETAIL

- INSTALL FIBER CONDUIT WITHIN THE FIBER HANDHOLE IN A SIMILAR FASHION AS THE PEDESTAL CONSTRUCTION DETAIL ABOVE.
- LEAVE THE LID OF THE FIBER HANDHOLE 3" ABOVE FINAL GRADE TO ALLOW FOR LANDSCAPING.

U46V - PEDESTAL SECTION DETAIL

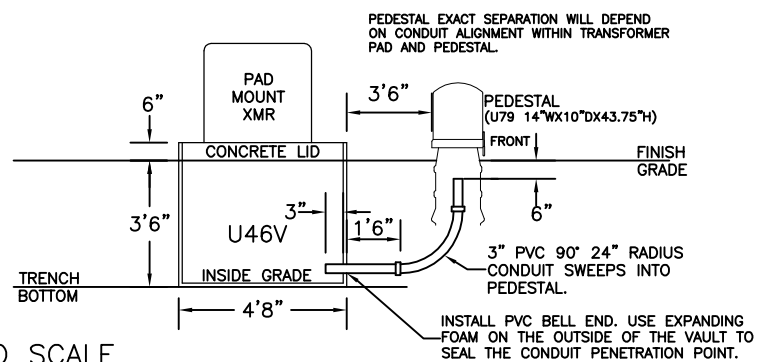

NOT TO SCALE

STREET LIGHT & HAND HOLE PLACEMENT

PROFILE VIEW

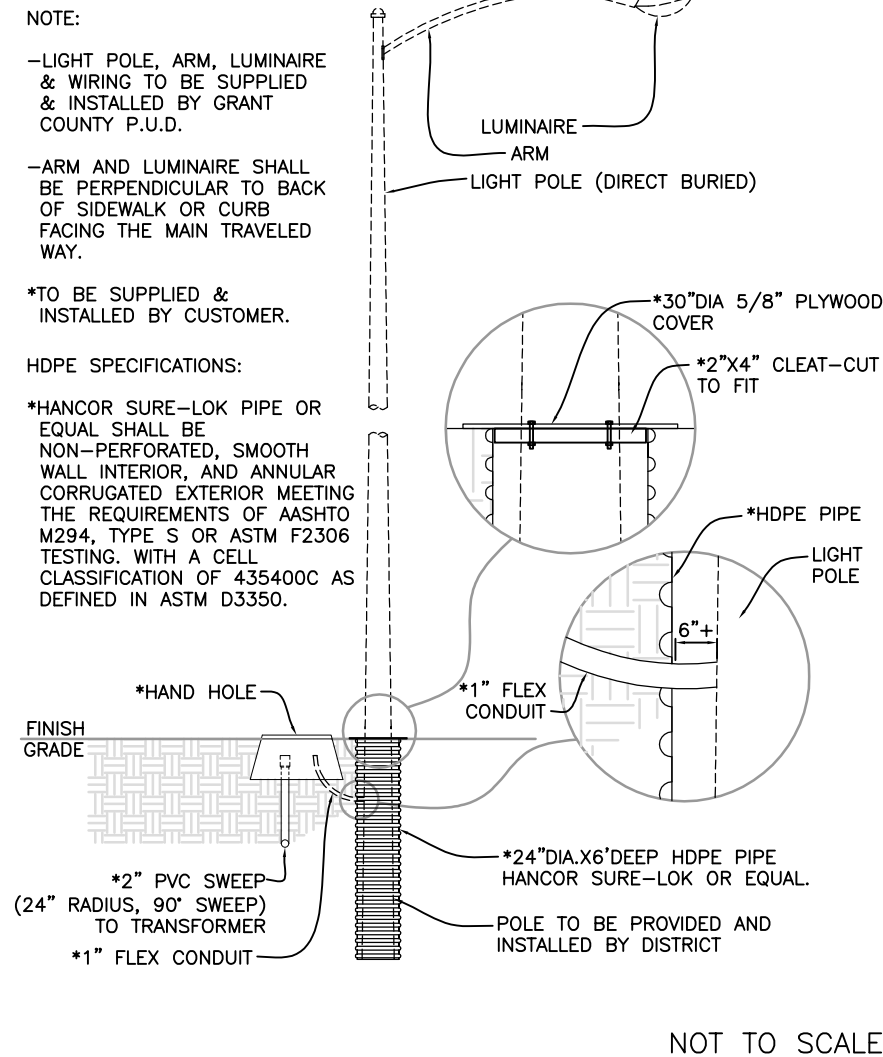

NOT TO SCALE

NOTE:

-LIGHT POLE, ARM, LUMINAIRE & WIRING TO BE SUPPLIED & INSTALLED BY GRANT COUNTY P.U.D.

-ARM AND LUMINAIRE SHALL BE PERPENDICULAR TO BACK OF SIDEWALK OR CURB FACING THE MAIN TRAVELED WAY.

*TO BE SUPPLIED & INSTALLED BY CUSTOMER.

HDPE SPECIFICATIONS:

*HANCOR SURE-LOK PIPE OR EQUAL SHALL BE NON-PERFORATED, SMOOTH WALL INTERIOR, AND ANNULAR CORRUGATED EXTERIOR MEETING THE REQUIREMENTS OF AASHTO M294, TYPE S OR ASTM F2306 TESTING. WITH A CELL CLASSIFICATION OF 435400C AS DEFINED IN ASTM D3350.

NOTES:

1. CUSTOMER TO PROVIDE ALL TRENCH, BACKFILL, CONDUIT, BEDDING, CONCRETE TRANSFORMER VAULTS, SWITCHING VAULTS, MOPEDS AND HAND HOLES TO GRANT COUNTY PUD SPECIFICATIONS.
2. INSTALL CAP AT END OF SPARE CONDUITS.
3. CORDINATE CONSTRUCTION WITH AREA LINE FOREMAN PHONE:
4. DEVELOPER TO PROVIDE ALL LOT CORNERS AND GRADE STAKES FOR CONSTRUCTION AND STAKING OF BURIED POWER LINES.
5. ALL SWITCHING VAULTS, TRANSFORMER VAULTS, AND HAND HOLES ARE TO BE INSTALLED AT FINAL GRADE PER GRANT COUNTY P.U.D. STANDARDS.
6. DEVELOPER TO COORDINATE WITH OTHER UTILITIES.
7. WARNING TAPE TO BE INSTALLED IN ALL TRENCHES 12"-16" ABOVE THE CONDUIT.
8. P.U.D. MUST INSPECT AND APPROVE ALL CONDUITS AND VAULTS BEFORE BACKFILL.
9. OBTAIN FIBER OPTIC CONDUIT, VAULTS, HAND HOLES, AND INSTALL PER GRANT COUNTY P.U.D. STANDARDS.

CONDUIT SPECIFICATIONS:

1. CONDUITS TO BE CENTERED AND ALIGNED TO PULL POWER CABLES DIRECTLY THROUGH KNOCKOUT ACCESS OPENING OF THE TRANSFORMER VAULT OR SWITCHING VAULT @ APPROXIMATELY 4" ABOVE INSIDE GRADE. PRIMARY CONDUITS SHALL ENTER AND EXIT @ OPPOSITE CORNERS OF VAULTS.
2. ALL MEDIUM HIGH VOLTAGE 36" RADIUS SWEEPS MUST BE MODIFIED TO EXTEND JUST ABOVE INSIDE GRADE @ TRANSFORMER VAULT OR SWITCH VAULT LOCATIONS.
3. USE FIBERGLASS OR GALV. STEEL SWEEPS FOR ALL PRIMARY CONDUIT.

CALL BEFORE YOU DIG 48 HOURS IN ADVANCE
DIAL 811 OR (1-800-424-5555)

DATE	APP2	APP1	ORG	CHK	DSH	DESCRIPTION
						PRELIMINARY New Drawing

REV.	3	2	1	A0
DESCRIPTION				

YELLOW BOOK
EXHIBIT DRAWING
DETAIL LAYOUT 2

TITLE	PRELIMINARY	SUB-CATEGORY	DATE	FILE	DATE	DATE	DATE
EXHIBIT-DWG			07/25/09				
EXHIBIT-DWG			07/25/09				
EXHIBIT-DWG			07/25/09				
EXHIBIT-DWG			07/25/09				

TYPICAL FIBER HAND HOLE/TRANSFORMER MOPED/STREET LIGHT/SWITCH VAULT PLACEMENT

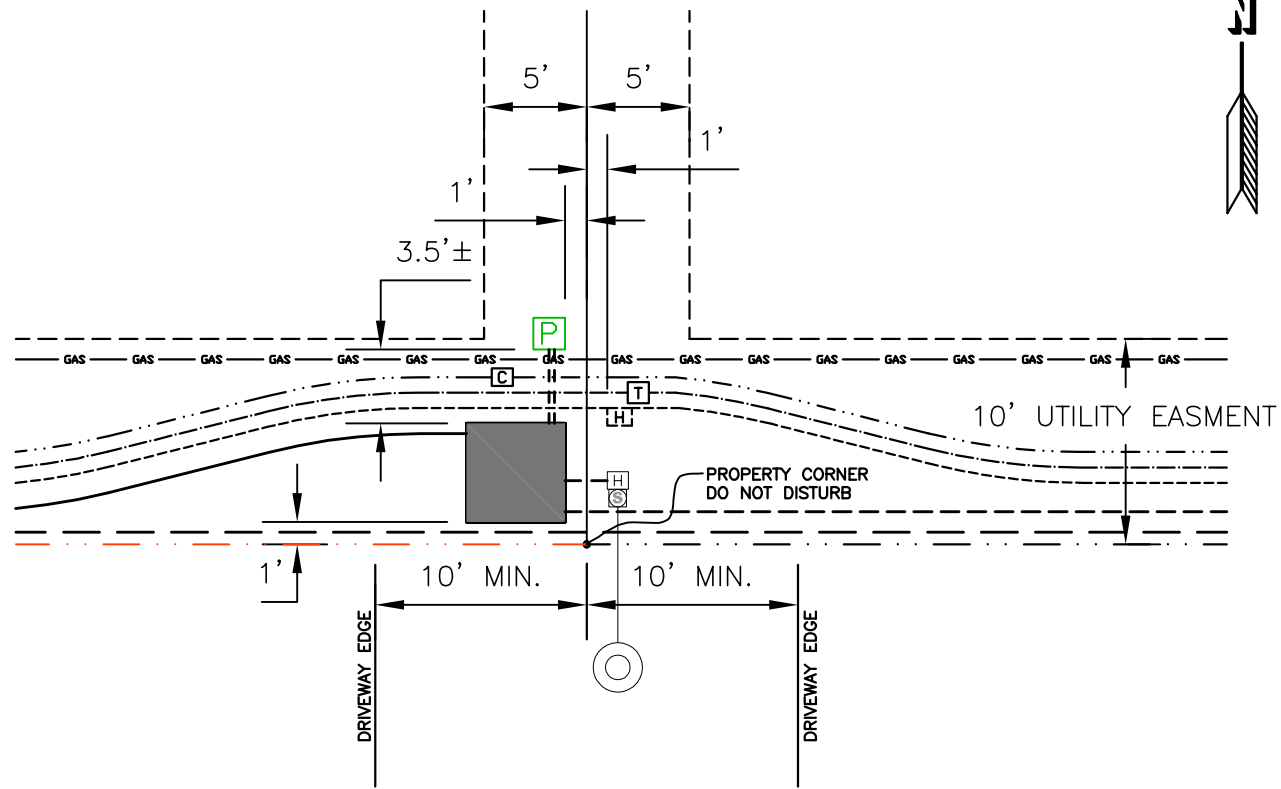

- GAS LINE
 - TELEPHONE, 4" PVC CONDUIT
 - CABLE, 2" PVC CONDUIT
 - FIBER OPTIC, 2" PVC CONDUIT
 - SECONDARY 3" PVC CONDUIT
 - STREET LIGHT, 2" PVC CONDUIT
 - SINGLE PHASE PRIMARY 2" PVC CONDUIT
 - THREE PHASE PRIMARY 4" PVC CONDUIT
 - PROPERTY LINE
 - UTILITY EASEMENT
 - ROAD CENTER LINE
 - RIGHT OF WAY: RIGHT OF WAY LINE POSITION SHOWN VARIES WITH ROAD WIDTH.
- U46V, TRANSFORMER PAD 4'8"SQX3'6"H W/OUT COVER
 - U54V, 1 PHASE SWITCHING VAULT 4'8"SQX3'6"H W/OUT COVER
 - U55V, 3 PHASE SWITCHING VAULT 6'LX4'WX4'H W/OUT COVER
 - U79, MO-PED 14"WX10"DX43.75"H
 - JU78, FIBER HAND HOLE 14"LX10"WX8"H
 - TELEPHONE PEDESTAL
 - CABLE PEDESTAL
 - STREET LIGHT & HAND HOLE

CALL BEFORE YOU DIG 48 HOURS IN ADVANCE
DIAL 811 OR (1-800-424-5555)

NOT TO SCALE

TYPICAL FIBER VAULT/TRANSFORMER MOPED/STREET LIGHT/SWITCH VAULT PLACEMENT

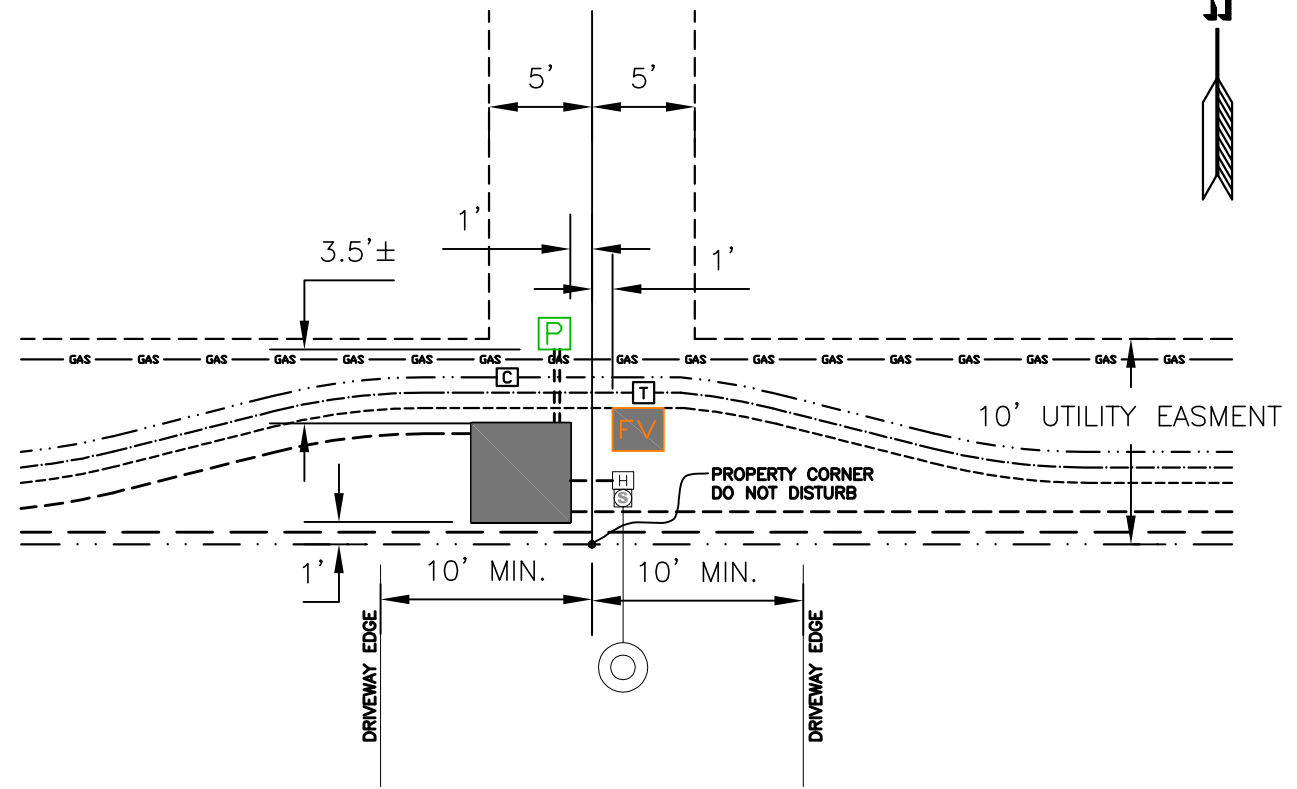

- GAS LINE
 - TELEPHONE, 4" PVC CONDUIT
 - CABLE, 2" PVC CONDUIT
 - FIBER OPTIC, 2" PVC CONDUIT
 - SECONDARY 3" PVC CONDUIT
 - STREET LIGHT, 2" PVC CONDUIT
 - SINGLE PHASE PRIMARY 2" PVC CONDUIT
 - THREE PHASE PRIMARY 4" PVC CONDUIT
 - PROPERTY LINE
 - UTILITY EASEMENT
 - ROAD CENTER LINE
 - RIGHT OF WAY: RIGHT OF WAY LINE POSITION SHOWN VARIES WITH ROAD WIDTH.
- U46V, TRANSFORMER PAD 4'8"SQX3'6"H W/OUT COVER
 - U54V, 1 PHASE SWITCHING VAULT 4'8"SQX3'6"H W/OUT COVER
 - U55V, 3 PHASE SWITCHING VAULT 6'LX4'WX4'H W/OUT COVER
 - U79, MO-PED 14"WX10"DX43.75"H
 - J230, FIBER VAULT 48"LX42"WX32"H
 - TELEPHONE PEDESTAL
 - CABLE PEDESTAL
 - STREET LIGHT & HAND HOLE

CALL BEFORE YOU DIG 48 HOURS IN ADVANCE
DIAL 811 OR (1-800-424-5555)

NOT TO SCALE

REV.	DESCRIPTION	DATE
3		
2		
1		
A0	PRELIMINARY New Drawing	

YELLOW BOOK
EXHIBIT DRAWING
DETAIL LAYOUT 3

DATE	BY	CHECKED	SCALE	PLANT
07/25/09				
07/07/09				

PRELIMINARY

EXHIBIT-DWG

EXHIBIT-DWG

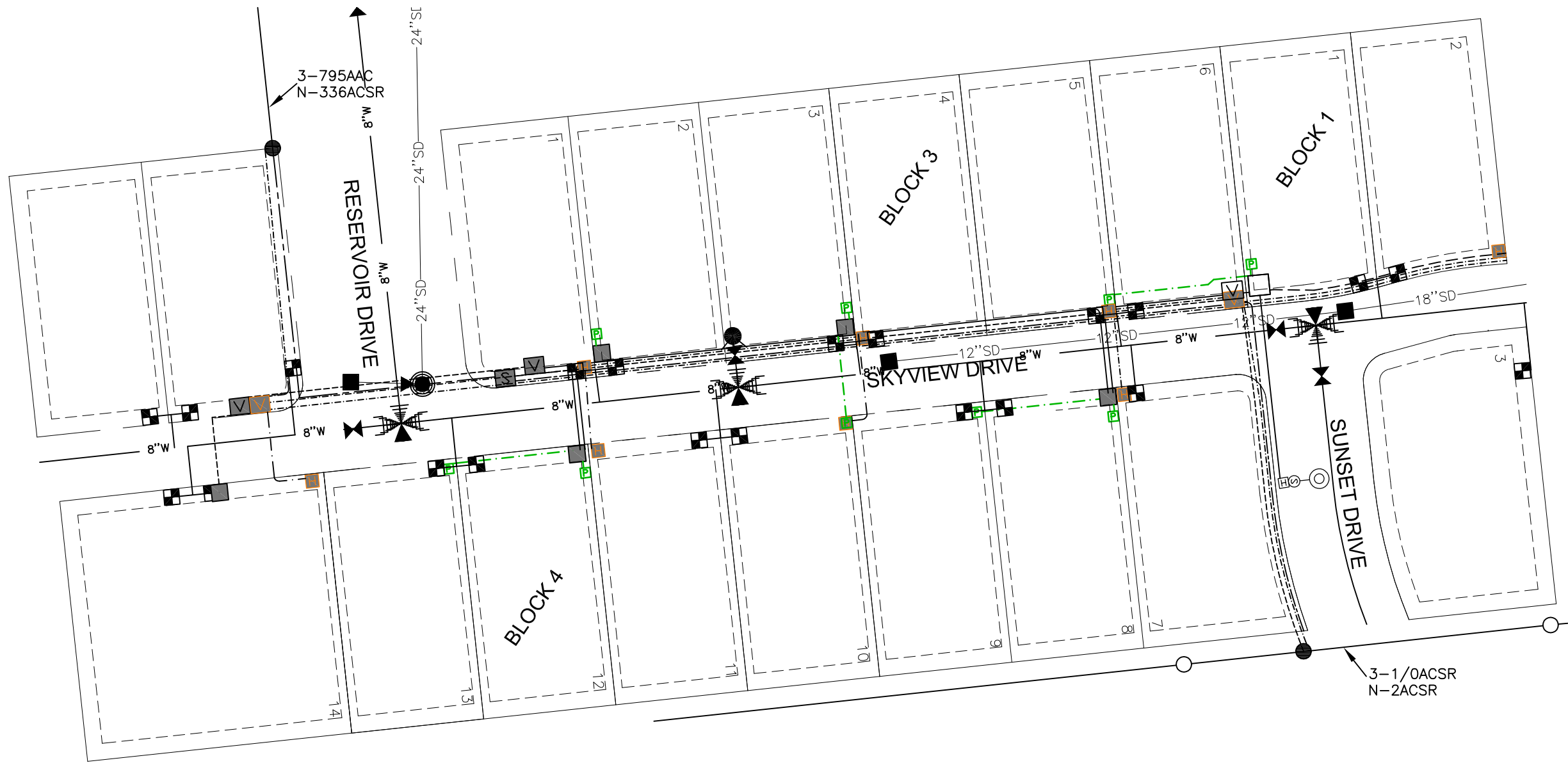

- CIVIL LEGEND**
- WATER SERVICE
 - STORM DRAIN
 - STORM DRAIN MANHOLE
 - FIRE HYDRANT
 - WATER VALVE
 - WATER TEE
 - 24" SD 24" STORMDRAIN
 - 18" SD 18" STORMDRAIN
 - 12" SD 12" STORMDRAIN
 - 8" W 8" WATER LINE
- LEGEND**
- NEW SWITCH VAULT
 - EXISTING SWITCH VAULT
 - NEW SWITCHGEAR VAULT
 - EXISTING SWITCHGEAR VAULT
 - NEW TRANSFORMER
 - EXISTING TRANSFORMER
 - PEDESTAL
 - NEW STREET LIGHT & HAND HOLE
 - RIGHT OF WAY
 - PROPERTY LINE
 - PUBLIC UTILITY EASEMENT
 - 2" SCH40 PVC CONDUIT
 - 3" SCH40 PVC CONDUIT
 - 4" SCH40 PVC CONDUIT
 - 6" SCH40 PVC CONDUIT
 - EXST. 1-PHASE POWER (IN CONDUIT)
 - EXST. 3-PHASE POWER (IN CONDUIT)



REV.	DESCRIPTION	DSH	CHK	ORG.	APP1	APP2	DATE
3							
2							
1							
A0	PRELIMINARY New Drawing						

YELLOW BOOK
 EXHIBIT DRAWING
 ALL COMBINED LAYOUT

CATEGORY	PRELIMINARY	SUB-CATEGORY	DATE	DATE	DATE
DWG FILE:	EXHIBIT-DWG		06/25/09		
DRAWN BY:	MAB	DESIGNED BY:	TCY	DATE:	06/07/09
DRAWING NUMBER:		SCALE:	10 TO 1	DWG. SIZE:	B

EXHIBIT-DWG

GCPUD CONSTRUCTION STANDARDS

16 pages are provided (without page numbers). Pages 39 thru 54

CONDUIT STANDARDS FOR CUSTOMER WORKBOOKS

Standard Cable Conduit Design and Application

SCOPE

This Construction Standard is intended to point out the special requirements necessary for proper installation of rigid and polyvinyl chloride (PVC) conduit for underground primary (13.2kV) and secondary (600volt) cable installation. This Standard also includes limits of conduit runs and pulling tensions.

1. Electrical Plastic Conduit (EPC-40)
 - a. PVC conduit (EPC-40) shall meet all requirements listed in NEMA Standard Publication TC 2, latest editions.
 - b. PVC fittings shall meet the requirements of NEMA Standard Publication TC 3 latest editions for Schedule 40 dimensions.
 - c. The solvent cement shall meet the requirements of ASTM D 2564 or it shall be in accordance with the conduit manufacturer's recommendations.

2. PVC Conduit Laying
 - a. All PVC conduit and fittings to be joined should be exposed to the same temperature conditions for a reasonable length of time before assembly. PVC conduit can expand or contract about 1" to 1-1/2" per 100 feet for every temperature change of 20 degrees.

Where a large difference between the temperature of the air and soil exists (air to damp trench), consideration should be given to making tie-ins at both manholes or vaults after the conduit bank has been covered a few hours in order to obtain a permanent connection to the manhole or vault.
 - b. PVC conduit entrance into manholes or vaults shall be horizontal for a length of 10' prior to being grouted into the inside wall of the manhole or vault. All PVC conduit shall be grouted on entrance to concrete manholes or vaults and end bells installed.
 - c. Where sidewall-bearing pressure will exceed 600 pounds, PVC or steel sweeps shall be concrete encased to a point 12 inches beyond the ends of the sweep couplings.

3. Cutting, Conduit and Preparing the Joint
 - a. Cutting the conduit square is important to insure a maximum bonding surface and to avoid a gap where the end meets the shoulder of the fitting. A fine - tooth saw shall be used to cut conduit (i.e. hacksaw for conduit 2 inches or less, wood saw for conduit greater than 2 inches). The conduit must be cut straight and cleaned of burrs.
 - b. Remove the burrs left by sawing with a knife or file. Remove all sharp edges on the O.D.

PUBLIC UTILITY DISTRICT NO. 2 OF GRANT COUNTY, WASHINGTON

CONSTRUCTION STANDARDS

STANDARDS COMMITTEE APPROVAL DATE:	2/28/01	Title: CONDUIT STANDARDS FOR CUSTOMER WORKBOOKS		
DESIGNER:	AJW			
STANDARDS ENGR:	E. WENKE	LAST REV.	06/25/18	Page 1 of 5

CONDUIT STANDARDS FOR CUSTOMER WORKBOOKS

and I.D. of the cut with a knife, file or other beveling tool to prevent possible injury to hands during handling and to prevent damage to cable during pulling. If burrs are not removed, inferior joint may result.

- c. Using a clean rag, wipe the pipe surface and fitting to be joined. Manufacturers in the process of belling pipe use a silicone release agent on the belling plug, and a residue of this agent can remain inside the bell. This must be removed in the cleaning process.
- d. Assembly of a cemented joint should be completed within 15 seconds after application of cement. Initial bonding begins immediately when the cement coated joint surfaces are in position.
If there is any sign of drying of the cement surfaces prior to assembly, precoat the duct spigot with a heavy even coat of cement and IMMEDIATELY, while cement is still wet, insert the spigot into the socket.

4. Conduit Selection

- a. The selection of a duct or conduit size for use with a given conductor size is influenced by a number of factors: duct fill, jamming ratio, side pressure, pulling tension, and friction.

TABLE 1. MAXIMUM CONDUIT FILL (SCHEDULE 40)

Conduit Size (Inches)	Inside Diameter (Inches)	1 Cable	2 Cables	3+ Cables
		53% fill (inches/sq)	31% Fill (inches /sq)	40% Fill (inches/sq)
1.0	1.049	0.458	0.268	0.346
2.0	2.067	1.778	1.040	1.342
3.0	3.068	3.918	2.292	2.957
4.0	4.026	6.74	3.946	5.092
6.0	6.065	15.312	8.956	11.556

For all sizes, combinations, and types of cable (except lead covered) to be installed in conduit, total cross sectional area taken by cables, including insulation, is not to be greater than the area specified in the table above.

Cable Fill:

Example: 3 each 1/0 primary cable. Diameter of 1/0 primary cable = 1.17 inches.

$$\text{Area} = \pi (1.17/2)^2 = 1.0746$$

$$3 \text{ Cables} = 1.0746 \times 3 = 3.22 \text{ square inches.}$$

In Table 1, select column with 3 or more cables 40% fill. The 3" conduit exceeds the 40% fill so 4" conduit is selected.

PUBLIC UTILITY DISTRICT NO. 2 OF GRANT COUNTY, WASHINGTON

CONSTRUCTION STANDARDS

STANDARDS COMMITTEE APPROVAL DATE:	2/28/01	Title: CONDUIT STANDARDS FOR CUSTOMER WORKBOOKS	
DESIGNER:	AJW		
STANDARDS ENGR:	E. WENKE	LAST REV.	06/25/18

CONDUIT STANDARDS FOR CUSTOMER WORKBOOKS

Jamming Ratio:

Conduit I.D./Cable O.D. (Cable O.D for 1 cable)

Check jamming ratio: $4.026/1.17 = 3.44$. **Jamming not likely...use 4" conduit.**

If Jamming Ratio is between 2.8 and 3.0 Jamming is probable and a larger size conduit is needed.

Sidewall Load Pressure:

Is the radial force exerted at a bend when cable is being pulled around a bend or sheave?

Exceeding the maximum sidewall load may subject the cable to crushing damage.

TABLE 2. MAXIMUM PULLING TENSION LIMITS, EPR 133% INSULATION

Cable Size	Cable O.D (Inches)	Conductor Grip		Basket Grip		Sidewall Bearing Pressure	
		Maximum Tension (lbs)		Maximum Tension (lbs)		Maximum (lbs)	
		Single Cond.	Three Cond.	Single Cond.	Three Cond.	Single Cond.	Three Cond.
1/0	1.17	850	1,650	850	1,000	500	1,000
4/0	1.32	1,700	3,400	1,000	1,000	500	1,000
350	1.50	2,800	5,600	1,000	1,000	500	1,000
750	1.96	6,000	10,000	1,000	1,000	500	1,000
1000	2.15	6,000	10,000	1,000	1,000	500	1,000

b. Guidelines for Conduit Sweeps:

1. **PVC Sweeps:**

All PVC sweeps shall be factory bent. Heating and bending of conduit is **prohibited**.

2. **Steel Sweeps:**

All steel sweeps and fittings shall be hot-dip galvanized. All steel sweeps shall be manufactured with an extrusion process.

3. **Fiberglass Sweeps:**

All fiberglass sweeps shall be equipped with 2 permanently attached deep pvc couplings.

4. **Flex Conduit Sweeps:**

Shall not be used except where specified for street lights.

5. Standard Radii for PVC and Steel Sweeps: The following standard radius sweeps are required as follows:

- Low voltage circuits in 2 and 3 inch conduit 36" radius

(Exception: 24" sweep will be allowed to enter a secondary pedestal or other equipment where a 36" sweep will not allow the pulling of cable.)

PUBLIC UTILITY DISTRICT NO. 2 OF GRANT COUNTY, WASHINGTON

CONSTRUCTION STANDARDS

STANDARDS COMMITTEE APPROVAL DATE:	2/28/01	Title: CONDUIT STANDARDS FOR CUSTOMER WORKBOOKS		
DESIGNER:	AJW			
STANDARDS ENGR:	E. WENKE	LAST REV.	06/25/18	Page 3 of 5

CONDUIT STANDARDS FOR CUSTOMER WORKBOOKS

- Low-voltage circuits in 4 inch conduit 36” radius
- Primary circuits in 2 or 4 inch conduit 36” radius
- Feeder circuits in 6 inch conduit 48” radius
- Individual feeder phases in 3 inch conduit 36” radius

5. Conduit Sweep Bends: Use of fiberglass or rigid steel elbows are required for all ends where conduit extends more than 150 feet in length or contains more than two (2) 90° bends installed by the customer and one (1) bend installed by the District. Total bends shall not exceed 270°.

c. Conduit Termination:

When installing Schedule 40 sweeps for primary and feeder cable at manholes, pull boxes, transformer box pads or transformer pads, a short section (minimum 8 inches) of conduit shall be installed on the end of each sweep to facilitate the use of (fit) the cable blowing (plug) tool. A short straight section of conduit is also required whenever an expandable plug or a “conduit and cable seal plug” is required.

All direct buried conduit to be terminated in the walls of a manhole, pull boxes, shall be approximately perpendicular to the walls and shall be grouted into the walls. After conduits have been properly aligned and terminated, proper compaction shall be attained to prevent shear stress on the conduit(s) at the point of entrance to the manhole or concrete handhole. Conduit(s) shall be terminated into manufacturer installed duct terminators or end bells.

Conduit installed through a building wall or into a customer’s vault shall be sealed (before and after the cable has been installed) internally and externally against the entry of noise, moisture and gas into the building or vault. After pulling primary or feeder cable into conduit, the conduit ends shall be sealed using foam Duo Fill 400 plastic filler.

Where cables exits a buried conduit sleeve or sweep, the cable shall be protected from the sharp conduit edge by chamfering the inside edge of the conduit sleeve or sweep and installing a cable leader guard (bell end). All exposed conduit ends shall be “covered” at the end of each work day to ensure a clean conduit run.

Stub outs or other exposed (above grade or not buried and not inside a locked enclosure) conduit ends that provide access to energized equipment shall be “glued and capped” unless construction crews are present. Conduit plugs (non-expandable type) shall be installed at all buried conduit stub-outs. Expandable conduit plugs shall be installed at all other newly installed conduit ends except where conduit is required to be “glued and capped”.

When a contractor leaves a conduit system (for more than one day) in which “others” will be responsible for installing the cable, any conduit ends left exposed shall be “primed, glued and capped” and conduit ends which are not exposed shall be sealed with expandable conduit plugs.

PUBLIC UTILITY DISTRICT NO. 2 OF GRANT COUNTY, WASHINGTON

CONSTRUCTION STANDARDS

STANDARDS COMMITTEE APPROVAL DATE:	2/28/01	Title: CONDUIT STANDARDS FOR CUSTOMER WORKBOOKS		
DESIGNER:	AJW			
STANDARDS ENGR:	E. WENKE	LAST REV.	06/25/18	Page 4 of 5

CONDUIT STANDARDS FOR CUSTOMER WORKBOOKS

When a contractor leaves a conduit system temporarily (for more than one day) but is also the responsible party which must later install the cable, then the conduit system can be plugged or can be primered, glued and capped at the contractor's discretion.

Where the Customer installs service conduit prior to the existence of District facilities and thus cannot complete the required connection (tie) to District facilities, the last 8 to 10 feet of the customer installed service conduit shall be left exposed and plugged, to facilitate the later connection to District facilities. Empty conduits which have been stubbed out by District for future attachment to customer may be located and exposed by the customer performing the attachment, provided there are not other District facilities within 2 feet and provided the clearance requirement from poles and anchors are met. To avoid misalignment of conduits when attaching to existing stubbed service conduit, the existing stubbed conduit ends should first be located to determine depth, then adjust the trench depth (if necessary) while trenching towards the service entrance section.

In direct-buried conduit systems, concrete encasement of conduit sweeps is required wherever the sidewall bearing pressure exceeds 600 pounds. The encasement shall be a minimum of 3 inches thick surrounding the sweeps and shall extend 12 inches beyond the sweep couplings.

Trenches shall be compacted to a minimum 95 percent of the maximum density as defined by AASHTO T99 or ASTM D 698 or ASTM D 2922 and D 3017, unless otherwise specified on the work order drawings or unless more stringent requirements prevail as dictated by local governmental agencies or other public regulatory agencies.

d. **Compaction Methods:**

1. See District Construction Standard No. 10.0010.
2. **Inspection and Inventory of Buried Units:**

Before backfilling, the contractor and District shall jointly inspect all trenches, conduit, cable placement, risers, pedestals transformer box pads and other construction not accessible after backfilling, and an inventory of units shall be taken. If corrections are required, a second inspection shall be made after completion of the changes.

8. **Fiber Optic Duct.**

- a. Fiber conduit will conform to the previous conduit standard with the following exceptions:
 1. Fiber conduit will be orange in color
 2. Fiber feeders will be 2"
 3. Fiber service drops will be 1"

PUBLIC UTILITY DISTRICT NO. 2 OF GRANT COUNTY, WASHINGTON

CONSTRUCTION STANDARDS

STANDARDS COMMITTEE APPROVAL DATE:	2/28/01	Title: CONDUIT STANDARDS FOR CUSTOMER WORKBOOKS		
DESIGNER:	AJW			
STANDARDS ENGR:	E. WENKE	LAST REV.	06/25/18	Page 5 of 5

TRENCH CONSTRUCTION, PVC CONDUIT**1. SCOPE:**

This specification covers trenching, trenching location in reference to other utilities, conduit location within the trench, backfill and compaction of backfill.

2. STANDARDS:

This specification includes reference to the following “*The American Society for Testing and Materials International*” (ASTM International) standards.

- 2.1. Soil Compaction:
ASTM D 698.00a Standard Test Methods for Laboratory Compaction Characteristics of Soil Using Standard Effort 12,400 ft.-lb/ft cubed.
- 2.2 Soil Classifications for Backfill:
ASTM D 2487-00 Standard Practice for Classifications of Soils for Engineering Purposes. (Unified Soil Classification System)
ASTM D 2488-00 Standard Practice for Description and Identification of Soils (Visual-Manual Procedure)

3. TERMINOLOGY:

- 3.1. Trench: Excavation for placement of individual conduits or duct systems for electrical and/or communication services.
- 3.2. Backfill Area: Area of trench backfilled in three zones- 1) Foundation 2) Embedment 3) Final Backfill Zone.
- 3.2.1. Foundation: Used only where the trench bottom is unstable or a material that does not compact. Additional compacted material may be added to make a secure base.
- 3.2.2. Embedment: Compacted material placed below, around and above the conduit/duct system to provide support and protection for the conduit/duct system..
- 3.2.2.a. Bedding: Material placed on the trench bottom or on foundation to provide uniform support and protection for the conduit(s)
- 3.2.2.b. Conduit Zone: Material placed on either side of the conduit and/or between ducts. This material prevents lateral displacement of the conduit/duct due to live loads or water infiltration.
- 3.2.2.c. Spring Line Cover: Six inches of material placed above the top of the

PUBLIC UTILITY DISTRICT NO. 2 OF GRANT COUNTY, WASHINGTON**CONSTRUCTION STANDARDS**

STANDARDS COMMITTEE APPROVAL DATE:	11/07/2002	Title: 10.0008 TRENCH CONSTRUCT PVC, CONDUIT	10.0008	
DESIGNER:	AJW			
STANDARDS ENGR:	E WENKE	LAST REV.	07/16/2004	Page 1 of 6

TRENCH CONSTRUCTION, PVC CONDUIT

conduit/duct system. This material provides protection for the conduit duct system from final backfill and/or live loads imposed on the trench.

- 3.2.3. Final Backfill: Trench area that extends from the top of the 6 inch cover to the top of the trench. Material here is native soil, unless the material contains cobbles or boulders over 4 inches in diameter.
- 3.3. Spring Line: The top of a single conduit or highest duct in the trench with more than one conduit.
- 3.4. PVC Conduit: Polyvinylchloride (PVC) conduit used for single conduit runs or duct systems. PVC conduit for electric systems will be grey. PVC conduit for fiber optic system shall be orange.
- 3.5. Definitions: This standard includes the definitions in ASTM 2487 and 2488, Section 3 “Terminology.”

4. BACKFILL MATERIALS:

General: All backfill materials are defined in ASTM 2487 & 2488, Section 3 ‘Terminology.’ All backfill used in any trench shall be organic-free material. This includes organic particles and larger organic debris.

- 4.1. Foundation Materials:
This material shall be compactible material such as gravel, sand, silt or clay or a mixture of those materials. Nothing larger than 1 inch minus gravel/aggregate shall be used. See ASTM 2487 & 2488, Section 3 “Terminology,” 3.1.2 “Gravel” (subsection “fine”)
- 4.2. Embedment Zone Materials:
Material in all three areas, bedding, conduit zone and cover, shall be sand, silt or clay material. Material shall pass a number 40 sieve but does not have to pass a number 200 sieve. Clay or Silt materials are defined as *fine grained top soil or soil free of any gravel, rock or rock chips*. See ASTM 2487 & 2488, Section 3 “Terminology,” 3.1.1 “Clay” & 3.1.7 “Silt.”
Sand is defined as *fine particles of rock, common reference “blow sand”*. See ASTM 2487 & 2488, Section 3 “Terminology,” 3.1.6 “Sand” (subsection “fine”)
- 4.3. Final Backfill Zone Materials
This material can in most cases be native soil/rock excavated from the trench. However if this material contains cobble/boulders larger than 4 inches in diameter it shall not be used.

5. CONSTRUCTION LOCATION/DIMENSIONS:

- 5.1. Location: The trench shall be within the easement granted to the District. The trench shall not be closer to other utilities than described below.

PUBLIC UTILITY DISTRICT NO. 2 OF GRANT COUNTY, WASHINGTON

CONSTRUCTION STANDARDS

STANDARDS COMMITTEE APPROVAL DATE:	11/07/2002	Title: 10.0008 TRENCH CONSTRUCT PVC, CONDUIT	10.0008
DESIGNER:	AJW		
STANDARDS ENGR:	E WENKE	LAST REV.	07/16/2004
			Page 2 of 6

TRENCH CONSTRUCTION, PVC CONDUIT

- 5.1.1. Water Lines: The electric trench shall be a minimum of 18 inches horizontally from any water line at any elevation.
- 5.1.2. Gas Lines: The electric trench shall be a minimum of 10 feet horizontally from any gas transmission line and 18 inches horizontally from any gas service line.
- 5.1.3. Sewer Lines: Where the sewer line is at or above the electric line elevation the horizontal separation shall be a minimum of 24 inches. If the sewer line is at a lower elevation than the electric line the trench shall be a minimum of 36 inches horizontally from the sewer line trench.
- 5.1.4. Communications: Communication lines, other than the District’s fiber optic cable, shall be located no closer to the primary or secondary electric lines than 12 inches. This is a radial measurement of 360 degrees.

5.2. Width:
 The minimum width of an electrical trench shall be 24 inches for a single conduit up to 4 inches in diameter. (See Figure # 1 in Section 7 under 7.1 Cross Section Dimension on page 5 of 6.) Trenches for conduit larger than 4 inches in diameter or with more than one conduit shall be determined by the conduit(s) placement in the trench. Minimum trench width shall be 5 times the diameter of a single conduit or 24 inches. (Which ever is larger).

5.3. Depth:
 The minimum depth of an electrical service trench shall be 36 inches for primary power, 30 inches for secondary power, and 36 inches for fiber optic cable. This depth shall be measured from the top of the conduit (Conduit Spring Line). The trench must be deep enough to place the foundation (if required) and bedding so the entire diameter of the conduit is below minimum grade. (Exceptions to this must have prior District approval and be installed as shown in this Standard. See Figure # 2 in Section 7 under 7.2 Concrete Encased Conduit on page 6 of 6.)

- 5.4 Backfill:
- 5.4.1 Foundation: Foundation where required shall be a minimum of 2 inches of compacted material. Foundation backfill does not need to be continuous provided compaction & cable protection is achieved.
 - 5.4.2 Bedding: Bedding shall be a minimum of 2 inches continuous compacted material and shall be constructed so the conduit is in contact with the bedding at all times.
 - 5.4.3 Conduit Zone: Conduit Zone depth shall be determined by the diameter of the conduit. The conduit zone shall be from the bedding to the spring line of the conduit and shall consist of material compacted along each side of the conduit. The material shall be

PUBLIC UTILITY DISTRICT NO. 2 OF GRANT COUNTY, WASHINGTON

CONSTRUCTION STANDARDS

STANDARDS COMMITTEE APPROVAL DATE:	11/07/2002	Title: 10.0008 TRENCH CONSTRUCT PVC, CONDUIT	10.0008	
DESIGNER:	AJW			
STANDARDS ENGR:	E WENKE	LAST REV.	07/16/2004	Page 3 of 6

TRENCH CONSTRUCTION, PVC CONDUIT

installed so there are no voids along the bottom sides of the conduit. Filling these voids shall be accomplished by shovel slicing, water compaction or other standard method.

5.4.4. Six Inch Cover: Cover zone shall be a minimum of 6 inches of compacted material.

5.4.5. Final Back Fill Zone: The final back fill zone shall restore the trenched area to the original contours with compacted native or barrow fill.

6. COMPACTION:

6.1. General Compaction:

All trench materials shall be compacted to 95% compaction. Compaction can be achieved by water, vibration or mechanical means. All material shall be compacted in 6 inch layers or as per ASTM D 698.

See ASTM D 698 for full requirements.

6.2. Zone Required Compaction:

6.2.1. Trench Bottom/Foundation: The trench base shall be compacted if excavated with a back hoe. All rake ridges shall be compacted or removed to undisturbed soil. If full or partial foundation is required it shall be added in minimal lifts and compacted to 95% compaction.

6.2.2. Bedding: The compacted (95%) two inches of bedding shall form a smooth pipe bed for uniform support of the conduit.

6.2.3. Conduit Zone: The compaction of the conduit zone shall be done in a manner that shall not damage or compress the conduit. Compaction shall be a minimum of 95%, as required.

6.2.4. Six Inch Cover: The conduit cover zone shall be in one lift and compacted to 6 inches @ 95% compaction.

6.2.5. Final Backfill: Final backfill requirements shall be determined by the material used and the land use over the trenched area. Compaction shall be a minimum of 95% with lifts that shall not exceed 8 inches regardless of the material employed as backfill.

6.2.5.1. Landscaped Areas: Any landscaped area shall be restored with acceptable top soil or native fill.

6.2.5.2. Parking Lot/Street: Any material and compaction under lots and/or streets shall be determined by the governing agency/owner.

6.2.5.3. Sidewalks/Curbs/Retaining Walls: Native fill shall be replaced with either 5/8 or 3/4 inch minus material that is compacted to full density.

PUBLIC UTILITY DISTRICT NO. 2 OF GRANT COUNTY, WASHINGTON

CONSTRUCTION STANDARDS

STANDARDS COMMITTEE APPROVAL DATE:	11/07/2002	Title: 10.0008 TRENCH CONSTRUCT PVC, CONDUIT	10.0008
DESIGNER:	AJW		
STANDARDS ENGR:	E WENKE	LAST REV.	07/16/2004
Page 4 of 6			

TRENCH CONSTRUCTION, PVC CONDUIT

7. DRAWINGS/DIAGRAMS/ILLUSTRATIONS

Figure #1 below is a typical trench layout cross sectional view showing the various zones and minimum required dimensions.

Figure #2 on page 6 of 6 is a cross section view of a concrete encased conduit. This method of reduced clearances is acceptable only with approval of District Staff.

7.1 Figure #1 Cross Section Dimension:

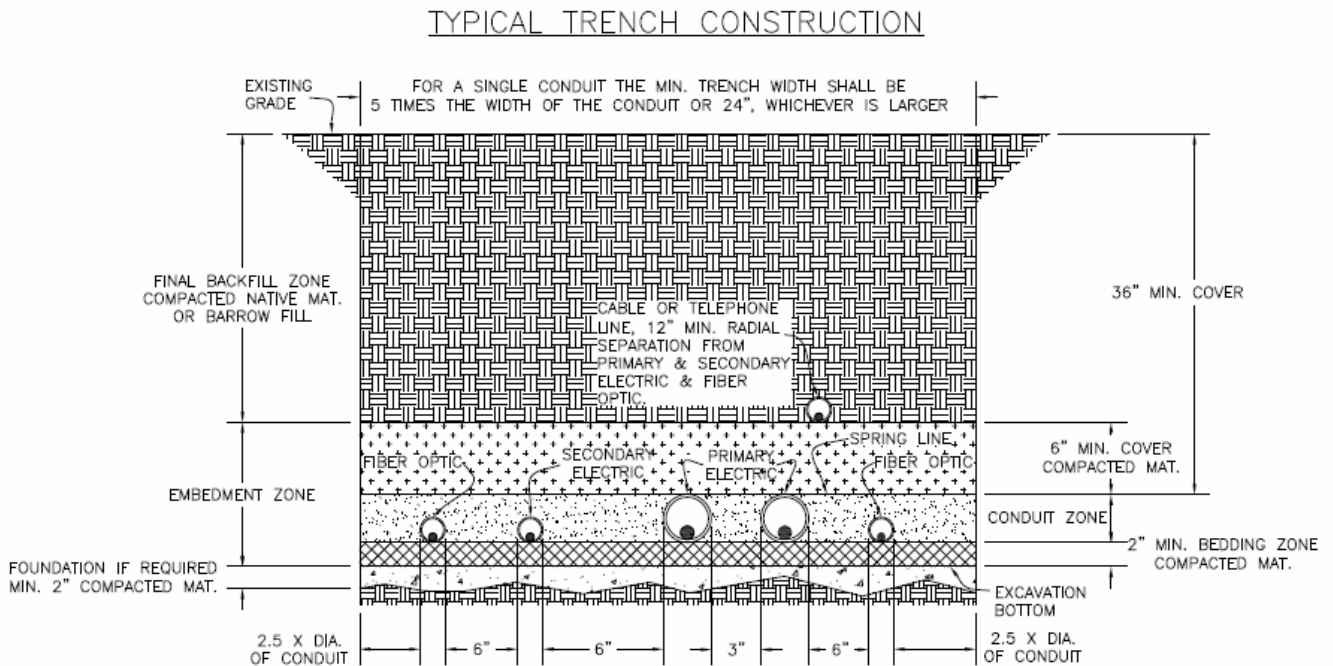

MULTI-CONDUITS SHALL BE CONFIGURED AS SHOWN.

NOTE:
ALL TRENCHING, TRENCH LOCATION IN REFERENCE TO OTHER UTILITIES,
CONDUIT LOCATION WITHIN THE TRENCH, BACKFILL AND COMPACTION OF
BACKFILL SHALL BE IN ACCORDANCE WITH ASTM INTERNATIONAL STANDARDS.

NOT TO SCALE

PUBLIC UTILITY DISTRICT NO. 2 OF GRANT COUNTY, WASHINGTON

CONSTRUCTION STANDARDS

STANDARDS COMMITTEE APPROVAL DATE:	11/07/2002	Title: 10.0008 TRENCH CONSTRUCT PVC, CONDUIT	10.0008
DESIGNER:	AJW		
STANDARDS ENGR:	E WENKE	LAST REV.	07/16/2004
			Page 5 of 6

TRENCH CONSTRUCTION, PVC CONDUIT

7.2 Figure #2 Concrete Encased Conduit

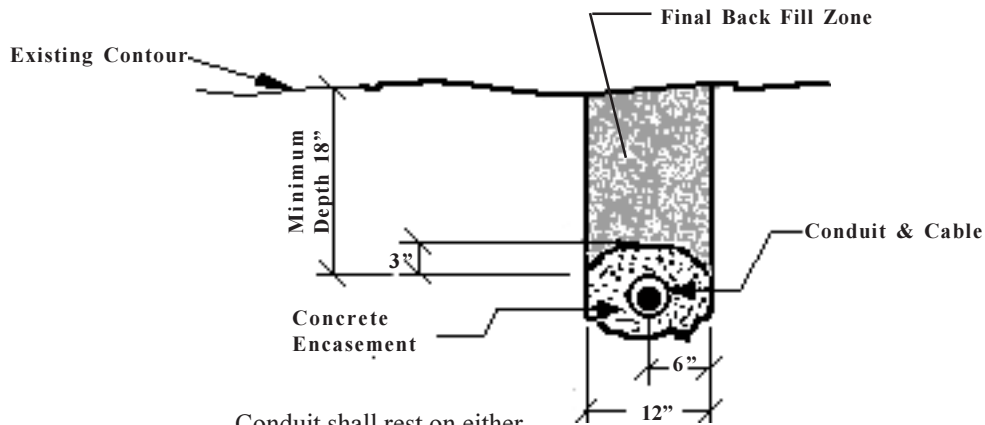

Conduit shall rest on either concrete or suitable foundation.
Concrete encasement shall be a 4 sack cement mix.

Notes:

1. Gas Transmission Lines require 10 feet of separation.
2. Horizontal Separation: Water/Gas Service lines must be a minimum of 18 inches from electric primary and secondary conductors.
Secondary conductors must be a minimum of 6 inches from primary conductors
Sewer shall be separated as per instruction in Section 5.1.3 of this document.
3. Radial Separation TV/Tele-Cable must be a minimum of 12 inches from primary and secondary conductors.
4. The District fiber optic conduit must be a minimum of 6 inches from the electric primary and secondary conductors and have a minimum radial separation of 12 inches from foreign cable/telephone utilities.

PUBLIC UTILITY DISTRICT NO. 2 OF GRANT COUNTY, WASHINGTON

CONSTRUCTION STANDARDS

STANDARDS COMMITTEE APPROVAL DATE:	11/07/2002	Title: 10.0008 TRENCH CONSTRUCT PVC, CONDUIT	10.0008
DESIGNER:	AJW		
STANDARDS ENGR:	E WENKE	LAST REV.	07/16/2004

CONCRETE TRANSFORMER BOX PAD INSTALLATION

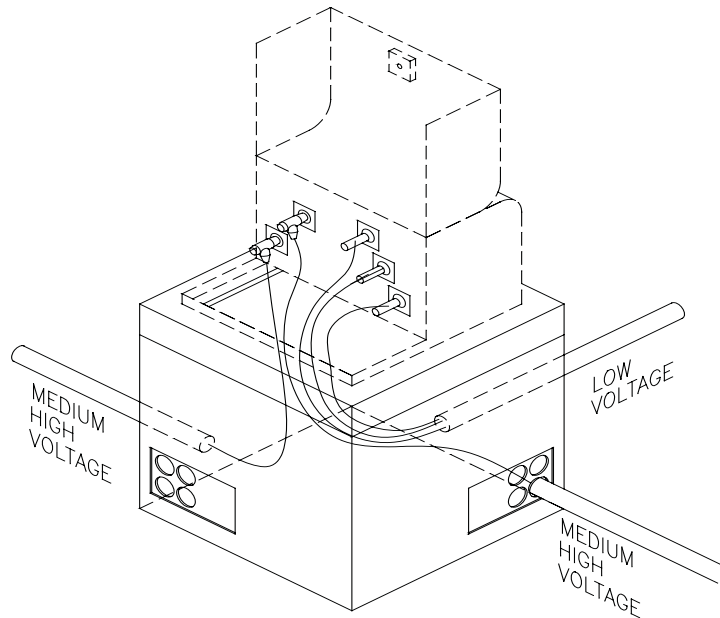

Figure 1. Concrete Transformer Vault (typical installation):

- All disturbed soil beneath the transformer vault shall be compacted.
- The bottom of the transformer box pad excavation shall be set level utilizing final grade.
- Backfilling shall not be performed until inspected and approved by Grant County PUD to ensure installation requirements have been met. Grounds, if necessary, shall be installed before backfill.
- Conduit, vault, and duct system shall not be displaced during backfilling and compaction.
- Conduit entering transformer box pads shall be supported in their proper position during backfill and compaction.
- The conduit for medium high voltage cable shall be positioned as indicated in the figures to allow for the incoming and outgoing conductor to coil around the inside of the vault in the same direction. Conduit for low voltage should be positioned to avoid cable pulling conflicts with the high voltage conductor and bushings.
- Developer shall be responsible for the replacement of any disturbed property corner pins. Property corner pins shall not extend more than 18 inches below final grade.
- Conduit shall be terminated as specified in the District's Conduit Specifications.
- Minimum clearance requirements and terrain limitations surrounding the transformer vault site should be 8 feet in front of the transformer and 3½ feet to the sides and back .

PUBLIC UTILITY DISTRICT NO. 2 OF GRANT COUNTY, WASHINGTON

CONSTRUCTION STANDARDS

STANDARDS COMMITTEE APPROVAL DATE:	05/24/01	Title: CONCRETE TRANSFORMER BOX PAD INSTALLATION		10.1130
DESIGNER:	AJW			
STANDARDS ENGR:	E WENKE	LAST REV.	06/25/18	Page 1 of 2

CONCRETE TRANSFORMER BOX PAD INSTALLATION

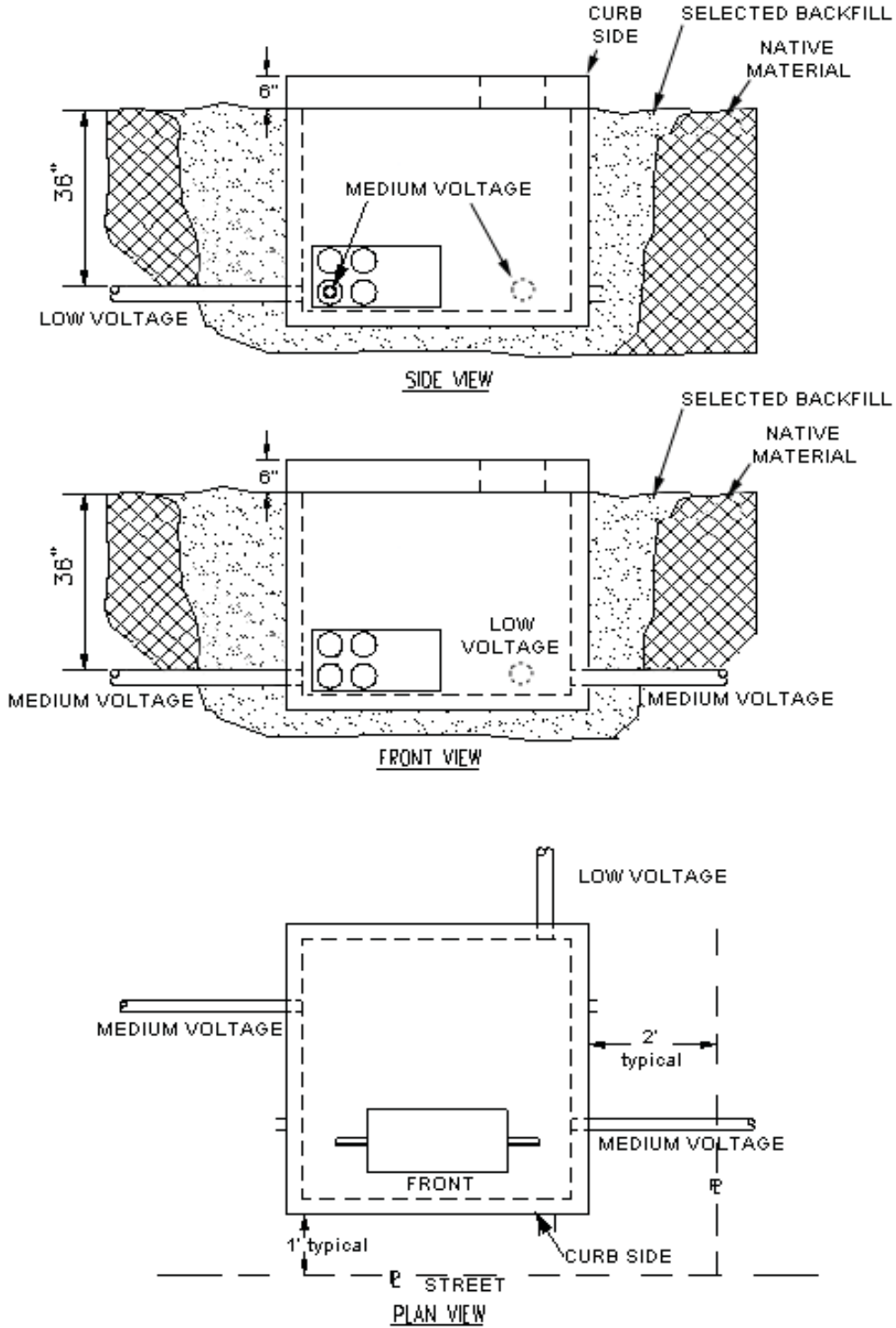

PUBLIC UTILITY DISTRICT NO. 2 OF GRANT COUNTY, WASHINGTON

CONSTRUCTION STANDARDS

STANDARDS COMMITTEE APPROVAL DATE:	05/24/01	Title: CONCRETE TRANSFORMER BOX PAD INSTALLATION	10.1130
DESIGNER:	AJW		
STANDARDS ENGR:	E WENKE	LAST REV.	04/23/09

SECONDARY PEDESTAL INSTALLATION

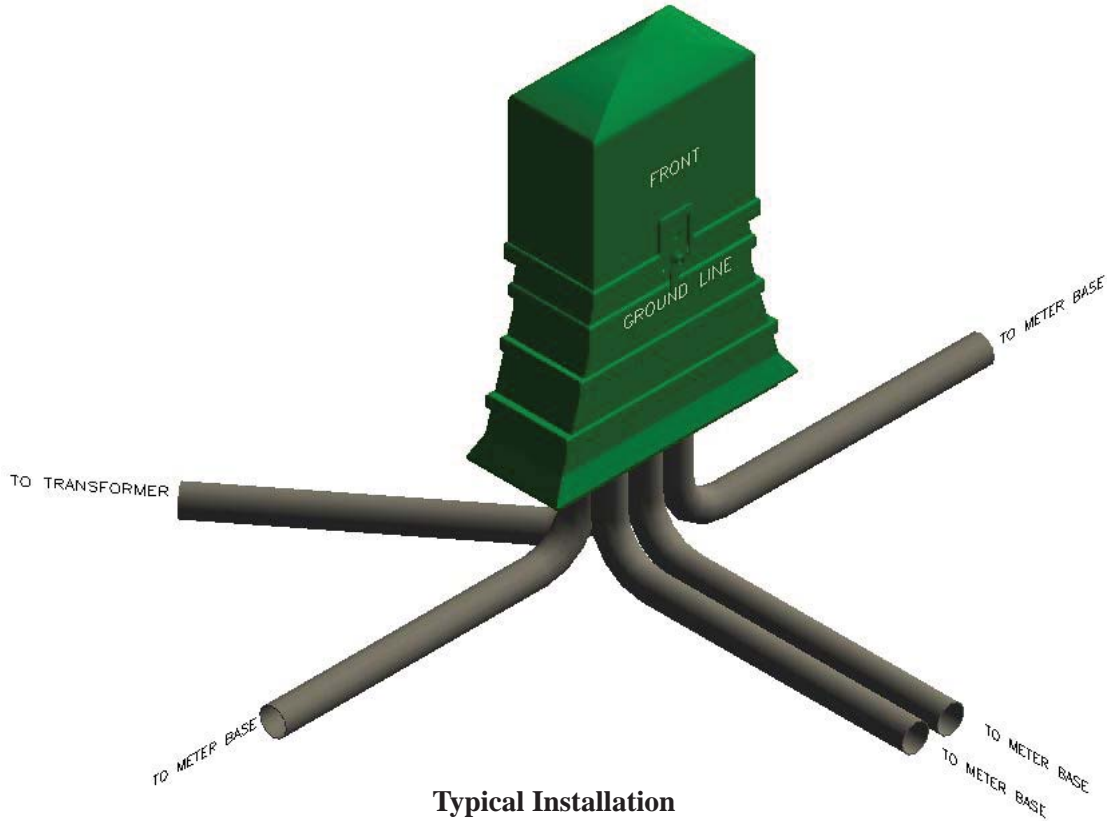

Typical Installation

- All disturbed soil beneath the secondary pedestal shall be compacted.
- The bottom of the secondary pedestal shall be set level utilizing final grade.
- Backfilling shall not be performed until inspected and approved by Grant County PUD to ensure installation requirements have been met.
- Conduit , vault, and duct system shall not be displaced during backfilling and compaction.
- Conduit sweeps into secondary pedestals shall be supported in their proper position during backfill and compaction.
- Developer shall be responsible for the replacement of any disturbed property corner pins. Property corner pins shall not extend more than 18 inches below final grade.
- Conduit shall be terminated as specified in the District’s Conduit Specifications.
- Minimum clearance requirements and terrain limitations surrounding the secondary pedestal site should be 8 feet in front of the transformer and 3.5 feet to the sides and back .
- Low voltage distribution cable/conduits system identification shall be installed.

PUBLIC UTILITY DISTRICT NO. 2 OF GRANT COUNTY, WASHINGTON

CONSTRUCTION STANDARDS

STANDARDS COMMITTEE APPROVAL DATE	03/15/01	Title: SECONDARY PEDESTAL INSTALLATION		10.1140
DESIGNER;	AJW			
STANDARDS ENGR.	E. WENKE	LAST REV.	04/23/09	Page 1 of 1

CONDUCTOR CLEARANCES FROM BUILDINGS (NOT ATTACHED)

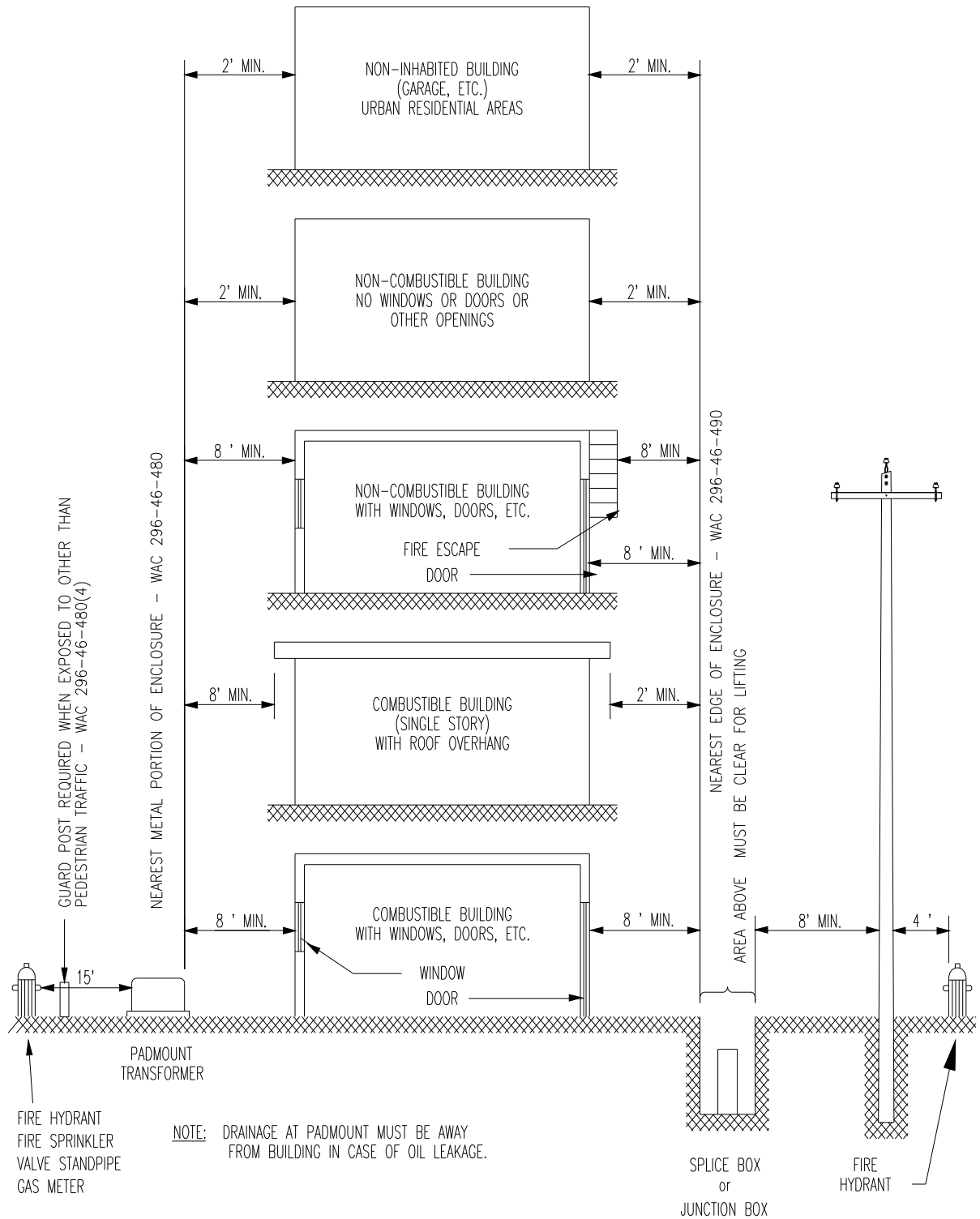

PUBLIC UTILITY DISTRICT NO. 2 OF GRANT, COUNTY WASHINGTON

CONSTRUCTION STANDARDS

STANDARDS COMMITTEE APPROVAL DATE:	1/27/97	Title: CONDUCTOR CLEARANCES FROM BUILDINGS (NOT ATTACHED)	19.0010
DESIGNER:	AJW		
STANDARDS ENGR:	x/x/xx	LAST REV.	8/21/01

CONDUCTOR CLEARANCES FROM BUILDINGS (NOT ATTACHED)

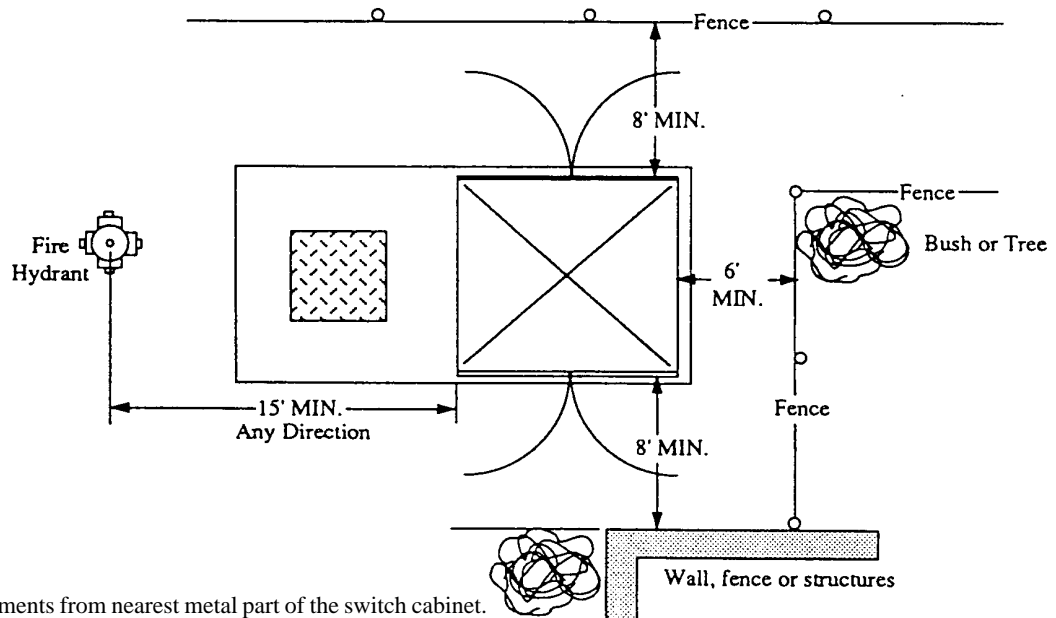
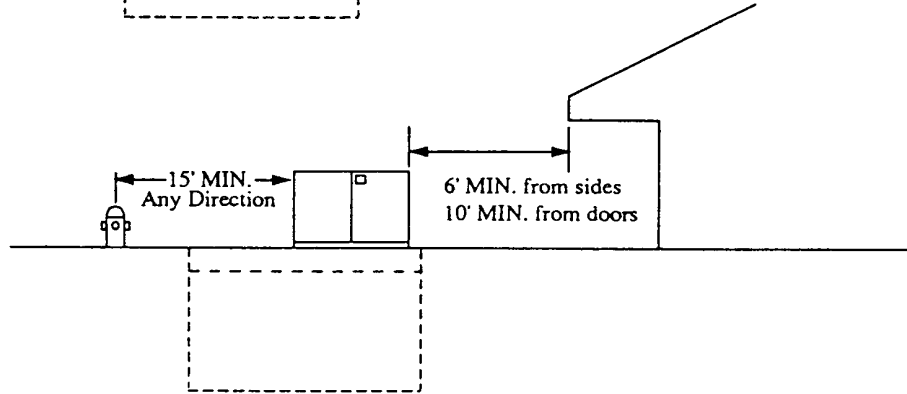
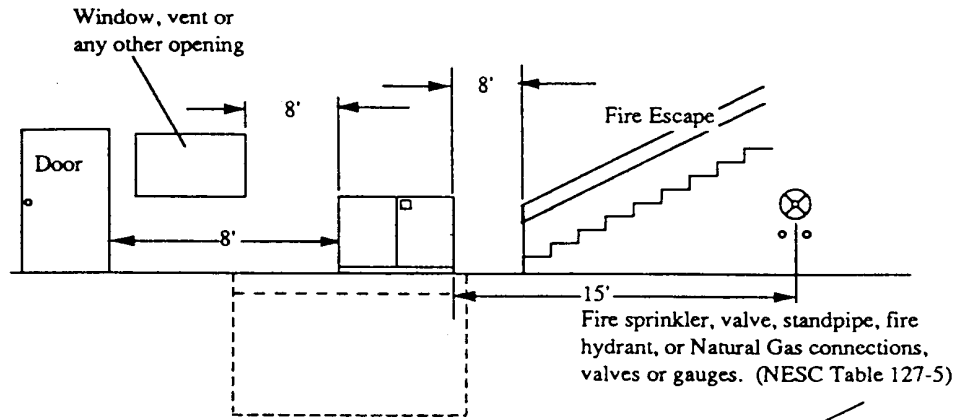

NOTES:

1. All measurements from nearest metal part of the switch cabinet.
2. Minimum 20' clearance from combustible fuel storage tanks.
3. Padmount equipment shall be not more than 15' from access road or driveway.
4. Landscaping which does not interfere with operation and maintenance of the switch cabinet is allowed.

PUBLIC UTILITY DISTRICT NO. 2 OF GRANT, COUNTY WASHINGTON

CONSTRUCTION STANDARDS

STANDARDS COMMITTEE APPROVAL DATE:	1/27/97	Title: CONDUCTOR CLEARANCES FROM BUILDINGS (NOT ATTACHED)		19.0010
DESIGNER:	AJW			
STANDARDS ENGR:	x/x/xx	LAST REV.	8/21/01	Page 4 of 6

ASSEMBLY UNITS

COMMON GCPUD ASSEMBLY UNITS

<u>ITEM#</u>	<u>STOCK#</u>	<u>DESCRIPTION</u>
A01C1E		1/0 AL EPR 15KV, 1 PHASE
A01C3E		1/0 AL EPR 15KV, 3 PHASE
A08C3E		1100 AL EPR 15KV, 3 PHASE
A10C		600V UG SNGL #6 AL
A36C		600V UG TRIPLEX AL, 2 - 350 & 1 - 4/0
J085		CONDUIT, SCH 40, FIBER OPTIC (ORANGE), 2"
J088		TRACER WIRE, #12 THHN ORG
J230		FIBER VAULT
JT32		CONDUIT, SCH 40 ELBOW 2" 90 DEG
JU78		FIBER HANDHOLE
L20		LIGHT 200W HPS 120V W/PC
LA12		12 FT STEEL MAST ARM, STREET LIGHT
LDB30		LIGHT DIRECT BURIED, STEEL STANDARD, 30 FT
LDB40		LIGHT DIRECT BURIED, STEEL STANDARD, 40 FT
LF1		LIGHT FUSE, BREAK-AWAY SINGLE
LV*	22097799	ENCLOSURE, LIGHTING JUNCTION BOX
LW		WIRE, CONDUIT, & ACCESORIES FOR LDB30-40, LPED30-40
T22*	76010720	CONDUIT, SCH 40 PVC, 2"
T13*	76010730	CONDUIT, SCH 40 PVC, 3"
T14*	76010740	CONDUIT, SCH 40 PVC, 4"
T16*	76010760	CONDUIT, SCH 40 PVC, 6"
T32*	76050320	CONDUIT, SCH 40 PVC ELBOW DB 2" X 36"R, 90 DEG
T32A*	76050318	CONDUIT, SCH 40 PVC ELBOW DB 2" X 24"R, 90 DEG
T33*	76050330	CONDUIT, SCH 40 PVC ELBOW DB 3" X 36"R, 90 DEG
T33A*	76050328	CONDUIT, SCH 40 PVC ELBOW DB 3" X 24"R, 90 DEG
T34*	76050340	CONDUIT, SCH 40 PVC ELBOW DB 4" X 36"R, 90 DEG
T42*	76060340	CONDUIT, SCH 40 PVC SWEEP DB 4" X 36"R, 45 DEG
T92*	76054020	CONDUIT, FIBERGLASS ELBOW 2" X 36"R - 90 DEG
T93*	76054030	CONDUIT, FIBERGLASS ELBOW 3" X 36"R - 90 DEG
T94*	76054040	CONDUIT, FIBERGLASS ELBOW 4" X 36"R - 90 DEG
T96*	76054060	CONDUIT, FIBERGLASS ELBOW 6" X 36"R - 90 DEG
T80*	83762700	SEALANT, INSTA-FOAM, 1 CU. FT. KIT

T82*	76670020	BELL END, 2" PVC
T83*	76670030	BELL END, 3" PVC
T84*	76670040	BELL END, 4" PVC
T86*	76670060	BELL END, 6" PVC
U46V*	22022374	VAULT, TRANSFORMER, 1 PHASE, 15-167KVA, 4'8" SQ. X 3'6"
	AND 22412478	COVER, TRANSFORMER, 1 PHASE, 15-167KVA, 4'8" SQ. X 3'6"
U47V*	22022374	VAULT, TRANSFORMER, 3 PHASE, 45-500KVA, 4'8" SQ. X 3'6"
	AND 22402486	COVER, TRANSFORMER, 3 PHASE, 45-500KVA, 4'8" SQ. X 3'6"
U54V*	22022374	VAULT, CONCRETE, SWITCHING, 1 PHASE, 4'8" SQ., 4'
	AND 22152378	COVER, VAULT, SWITCHING, 1 PHASE, 4'8" SQ., 4'
U55V*	22022462	VAULT, CONCRETE, SWITCHING, 3 PHASE, 4'8" X 4'8" X 4'
U56SG*	22022092	VAULT, CONCRETE, SWITCHGEAR, 9' X 5' X 7'2"
U56V*	22023083	VAULT, CONCRETE, SWITCHING, 3 PHASE, 9' X 5' X 7'2"
U59		JUNCTION BUS, 4 POS
U69		CAP, PROTECTIVE GROUNDED
U79*	44402439	PEDESTAL, SECONDARY - ABOVE GROUND
U84TEP		CONNECTOR, ELBOW, 1/0 AL EPR, 15KV LOADBREAK W/TEST POINT
UFIV03		FAULT INDICATOR UG TPR 300A 1P
UA1*	81040700	MARKER, UNDERGROUND INSTALLATIONS
UA9*	83271800	GUARD POST

* Customer responsibility to provide

SEE GRANT COUNTY P.U.D. PARTS CATALOG FOR ITEMS NOT LISTED ABOVE. /

STOCK PAGES

40 pages are provided (without page numbers). Pages 58 thru 97

SEALANT, INSTA-FOAM KIT



GENERAL: Two-component, quick cure polyurethane foam to fill cavities, holes, and cracks.

SPECIFICATIONS: The kit shall include pressurized "A" and "B" cylinders, dispensing gun and hose assembly, and extra nozzles. The A cylinder shall contain polymeric isocyanate and the B cylinder shall contain a polyol blend. The foam shall expand immediately upon chemical reaction of A component and B component, to a final volume that is 3 to 5 times the dispensed volume. The foam shall cure to a semi-rigid form and be tack-free in about 1 minute, cuttable in about 5 minutes and fully cured in approximately 1 hour.

The nozzles shall fit the Froth-Pak 12 Insta-flo run. The nozzles shall be a cone type with a medium flow output. The nozzles shall be identified by a white base and clear body.

PURCHASING: UOM: Each

STOCK NUMBER	DESCRIPTION	YIELD (approx.)	APPROVED MANUFACTURERS & CATALOG NUMBERS
			DOW CHEMICAL
83762700	FOAM	1 cu. ft.	FROTH-PAK 12
83762800	FOAM	17 cu. ft.	FROTH-PAK 200
83763000	NOZZLES	25 pk.	259211

Rev. 09-05-13 DH "Removed Fomo Handi-Foam as approved."
 Rev. 02-24-12 DH "Added Fomo Products as approved; Changed Flexible Products to Dow Chemical; updated catalog numbers."
 Rev. 10-18-02 EEA "Deleted Duo Fill 400."
 Rev. 11-03-00 LW "Changed catalog number for 8376300."

PUBLIC UTILITY DISTRICT #2 OF GRANT COUNTY	Date	05/18/87	SEALANT, INSTA-FOAM KIT				ASSEMBLY UNIT		Yes			
	Rev #	7					TDSI		X	TTNI	TMNI	TSNI
	Designer	LJ					83762700					
	Standards Engineer	Al Silva										

MARKERS, UNDERGROUND INSTALLATIONS



Mid-Range Marker
Approx. 8-1/4"
#81040700



Full Range Marker
Approx. 15"
#81040800

- GENERAL:** Markers for use of identifying any of the following: service drops, buried junctions, buried transformers, conduit stubs, road crossings, repair points, and snow covered installations.
- SPECIFICATIONS:** Red Polyethylene cover over nontoxic environmentally safe solution for self leveling of filament. 40 year life required. Red is the required electric marker color. Broadcast band width is 169.8 kHz
- MAX. DEPTH:** 81040700 - 6 ft.
81040800 - 6 ft.
- INSTALLATION:** Shall not be buried greater than specified depth.
The marker should be at least 6 inches above buried object - flat and level.
Cover the marker with 4 inches of soil before back fill work is done.
*To be used with Scotchmark II Electronic Marker Locator.

STOCK NUMBER	APPROVED MANUFACTURERS & CATALOG NUMBER	
	3M ScotchMark	
81040700	1256	
81040800	1251	

Rev. 05-31-01 MHS "Added electric specifications including band width."
Rev. 07-29-96 LL - Adding reference to electronic Marker Locator.

PUBLIC UTILITY DISTRICT NO. 2 OF GRANT, COUNTY WASHINGTON

MARKERS, UNDERGROUND INSTALLATION

DATE:	03/16/88	STOCK CATALOG	<input checked="" type="checkbox"/> TDSI	81040700
DESIGNER;	LL		<input type="checkbox"/> TINI	
STANDARDS ENGR;	A. Silva		<input type="checkbox"/> TMNI	
			<input type="checkbox"/> TSNI	Page 1 of 1

POST CONC 9" DIA. 72" LONG

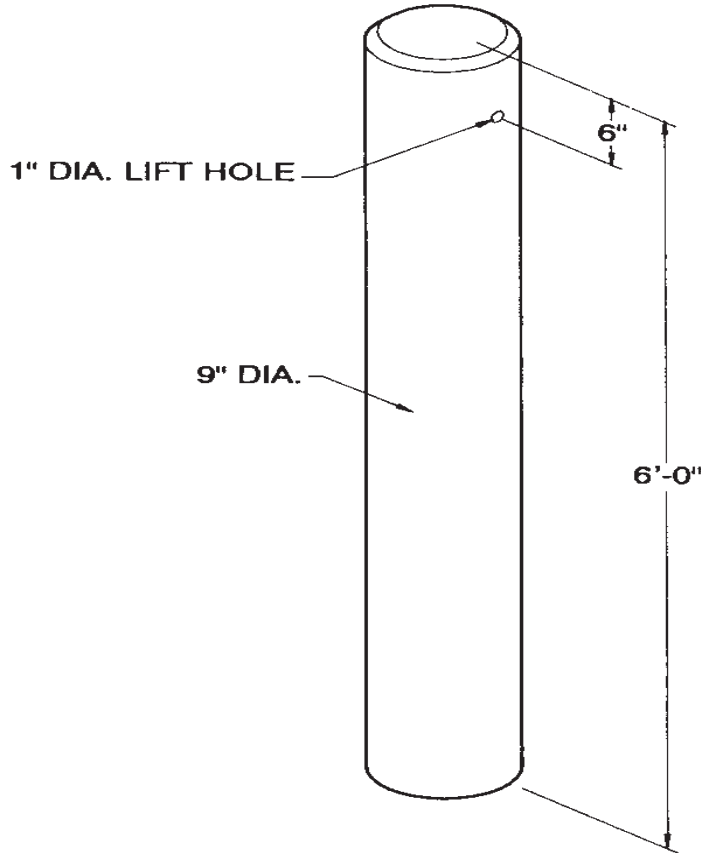

Guard Post
398 lbs.

STOCK NUMBER	APPROVED MANUFACTURERS & CATALOG NUMBER
	UTILITY VAULT COMPANY
83271800	GUARD POST

Rev. 02-05-92 MG - Added drawing. Changed size from 8" dia. 64" long to 9" dia. 72" long. Added Utility Vault Co. and deleted Columbia Concrete and Spokane Concrete.
 Rev. 04-22-85 KB - Added Spokane Concrete Products.

PUBLIC UTILITY DISTRICT NO. 2 OF GRANT, COUNTY WASHINGTON

POST CONC. 9" DIA. 72" LONG

DATE:	07/11/77	STOCK CATALOG	<input checked="" type="checkbox"/> TDSI	83271800
DESIGNER;	A.S		<input type="checkbox"/> TINI	
STANDARDS ENGR;	A. SILVA		<input type="checkbox"/> TMNI	<input type="checkbox"/> TSNI

BELL, END PVC Fitting

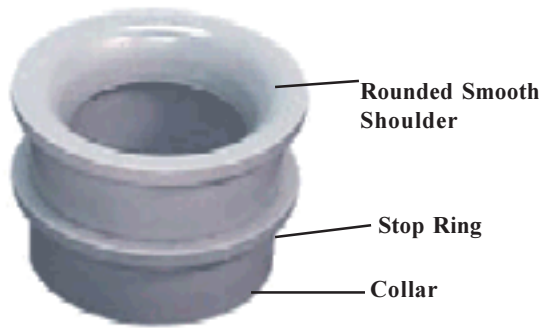

Bell End Photo

GENERAL: Bell ends designed to create a smooth end for PVC conduit in vaults, risers or other end of run areas. Used to protect cable insulation from abrading or other damage.

SPECIFICATIONS: Bell ends shall be made from PVC {Polyvinylchloride} with inert modifiers to improve weatherability. All fittings shall conform to NEMA TC-3 and UL 514. Only bell ends form molded to have round smooth shoulders will be accepted. Each end must have an insert collar with molded stop.

SIZE: See Table for sizes

PURCHASING: Standard Pkg is listed for Can-Tex. Order like numbers from other manufacturers.

STOCK NUMBER	SIZE	Std. Pkg.	APPROVED MANUFACTURERS & CATALOG NUMBER			
			Can-Tex	Kraloy	Carlton	RaceTec
76670010	1"	50	5144005	MEB10	E997F-CAR	End Bells*
76670020	2"	40	5144008	MEB20	E997J-CAR	End Bells*
76670030	3"	50	5144010	MEB30	E997L-CAR	End Bells*
76670040	4"	50	5144012	MEB40	E997N	End Bells*
76670060	6"	15	5144014	MEB60	E997R	End Bells*

* Race Tec orders must list size and quantity.

Rev. 10-22-02 EA "Added 1" size changed page # to lowest stock number, deleted Certaineed"

Rev. 09-15-95 LL "Added 2-1/2"

PUBLIC UTILITY DISTRICT NO. 2 OF GRANT, COUNTY WASHINGTON

BELL, END

DATE:	06/19/90	STOCK CATALOG	<input checked="" type="checkbox"/> TDSI	76670010
DESIGNER;	GW		<input type="checkbox"/> TINI	
STANDARDS ENGR;	AL SILVA		<input type="checkbox"/> TMNI	
			<input type="checkbox"/> TSNI	Page 1 of 1

ADAPTER, PVC TO THREADED METALLIC, FEMALE

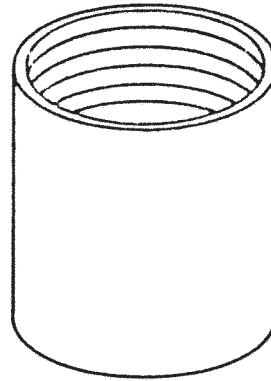
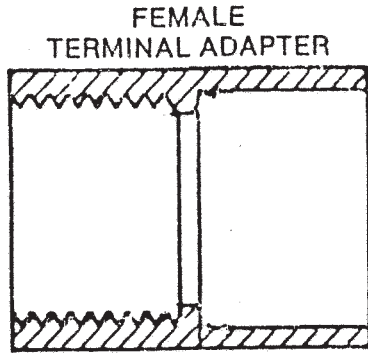

GENERAL: Socket type female terminal for rigid and DB PVC ducting. Fittings must conform to ANSI/NEMA Specification TC 3, "PVC Fittings for use with Rigid PVC Conduit and Tubing".

SIZE: As noted below.

PURCHASING: Quantity Each.

STOCK NUMBER	SIZE (IN)	APPROVED MANUFACTURERS & CATALOG NUMBER				
		CARLON	CERTAINTED	KRALOY	CAN-TEX	RACETEC
76320007	3/4	E 942 E	59631	FA07	5140044	FEMALE ADAPTER*
76320010	1	E 942 F	59632	FA10	5140045	FEMALE ADAPTER*
76320015	1-1/2	E 942 H	59634	FA15	5140047	FEMALE ADAPTER*
76320020	2	E 942 J	59635	FA20	5140048	FEMALE ADAPTER*
76320025	2-1/2	E 942 K		FA25	5140049	FEMALE ADAPTER*
76320030	3	E 942 L	59637	FA30	5140050	FEMALE ADAPTER*
76320040	4	E 942 N	59639	FA40	5140052	FEMALE ADAPTER*
76320050	5	E 942 P	59640	FA50	5140053	FEMALE ADAPTER*
76320060	6	E 942 R	59641	FA60	5140054	FEMALE ADAPTER*

Rev. 09-15-95 L.L. "Added 2-1/2"
 Rev. 08/13/92 J.H. "Added RaceTec and catalog numbers."

PUBLIC UTILITY DISTRICT NO. 2 OF GRANT, COUNTY WASHINGTON

ADAPTER, PVC TO THREADED METALLIC, FEMALE

DATE:	07/10/89	STOCK CATALOG	<input checked="" type="checkbox"/> TDSI	76320007
DESIGNER:	HC		<input type="checkbox"/> TINI	
STANDARDS ENGR:	A. Silva		<input type="checkbox"/> TMNI	
			<input type="checkbox"/> TSNI	Page 1 of 1

ELBOW, FIBERGLASS SWEEP 90 DEGREE

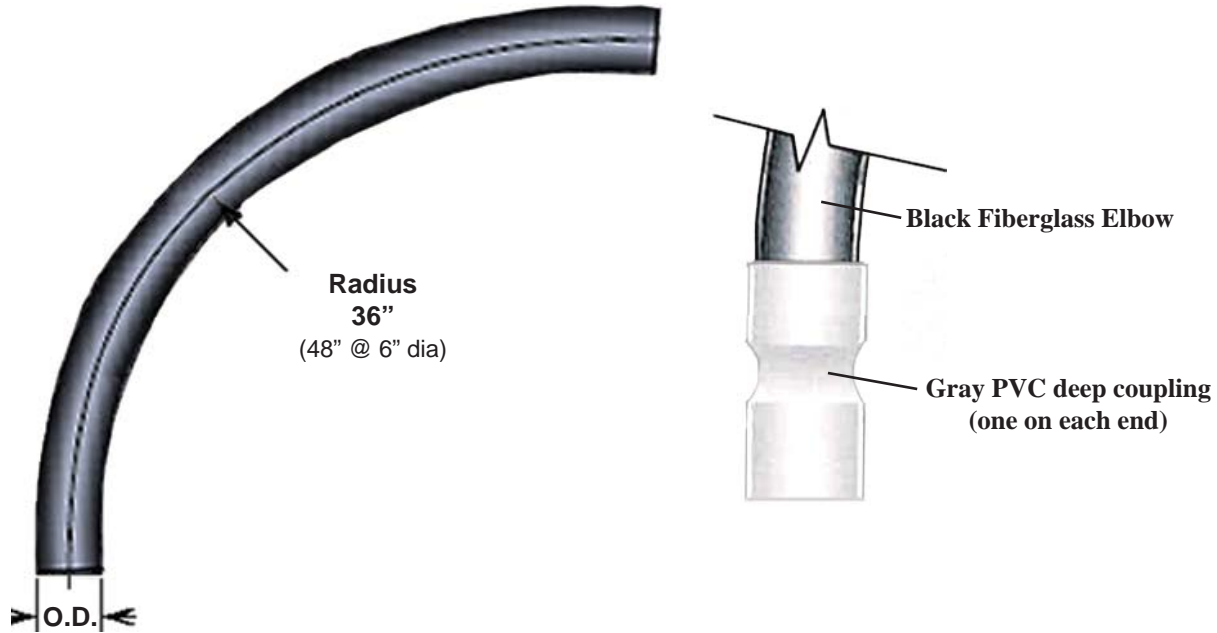

GENERAL: 90 degree fiberglass elbows in rigid nonmetallic conduit configurations for underground sweeps in distribution and transmission applications.

SPECIFICATIONS: Elbows shall be formed from Champion Fiberglass™ reinforced epoxy resin conduit, manufactured using the single filament wound system, with a radius of 90° ± 1°. Glass shall be E-type and the glass content shall be 70% ± 5% as per API SPEC 15 LR. The resin shall be epoxy without fillers. Elbows shall be IPS above ground type and be fire resistance per UL 1684 and CSA-C22, No. 211.3. Elbow shall be usable for below ground as well as above ground. Each elbow shall be equipped with two (2) permanently attached deep PVC couplings.

RATINGS:	Tensile Strength (Axial)	11,000 psi	ASTM D2105
	Compressive Strength (Axial)	12,000 psi	ASTM D695
	Barcol Hardness	54 ± 2	ASTM D2583

PURCHASING: Quantity "Each"

STOCK NUMBER	SIZE (inches)	WALL TYPE	O.D. (inches)	IMPACT VALUE (lb per ft)	STIFFNESS VALUE (32°-74° F)	APPROVED MANUFACTURERS & CATALOG NUMBERS	
						CHAMPION	RACEWAY TECH
76054020	2	STANDARD	2.14	40	320	20C-SW-92-2D	FG-029036RW
76054030	3	STANDARD	3.14	70	140	30C-SW-92-2D	FG-039036RW
76054040	4	HEAVY	4.19	120	130	40C-HW-92-2D	FG-049036RW
76054060	6	HEAVY	6.60	200	65	60C-HW-93-2D	FG-069048RW

Rev. 12-31-15 SW "Added Raceway Technologies as approved mfg"
 Rev. 11-02-10 DH "Changed catalog numbers and specification to Above Ground type for fire resistivity."
 Rev. 04-09-10 MHS "Removed United Fiberglass/Raceway as approved mfg."
 Rev. 05-18-07 DH "Added United Fiberglass/Raceway as approved mfg.; added O.D."

PUBLIC UTILITY DISTRICT #2 OF GRANT COUNTY	Date	12/19/02	ELBOW, FIBERGLASS SWEEP 90 DEGREE	ASSEMBLY UNIT		Yes		
	Rev #	6						
	Designer	MHS		TDSI	X	TTNI	TMNI	TSNI
	Standards Engineer	E. WENKE		76054020				

ELBOW, SCHEDULE 40 PVC, 90 DEGREE

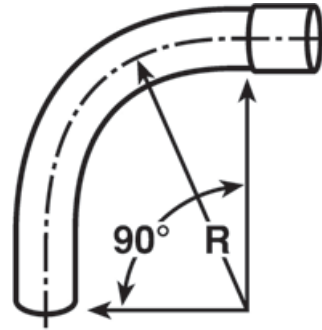

GENERAL: Schedule 40 PVC belled end 90 degree elbow for overhead or underground installations.

SPECIFICATIONS: The elbow shall be made from PVC resin in accordance with NEMA TC-2 and UL 651. The elbow shall have one integral bell end with the minimum depth required per UL 651 as shown below.

PURCHASING: UOM: Each

STOCK NUMBER	SIZE	RADIUS (R) inches	UL 651 Min. BELL DEPTH (inches)	APPROVED MANUFACTURERS & CATALOG NUMBERS				
				CANTEX	CARLON	PRIME	JM EAGLE	RIDGELINE
76050307	3/4	4 1/2	23/32	5233824	UA9AEB	UA9AEB	75900075	F4007590
76050309	1	18	7/8	----	UA9CFB	UA9CFB	7590180100	F401009018
76050310		5 3/4		5233825	UA9AFB	UA9AFB	75900100	F4001090
76050316	2	18	1 1/8	5233846	UA9CJB	UA9CJB	7590180200	F402009018
76050318		24		5133924	UA9DJB	UA9DJB	7590240200	F402009024
76050320		36		5233848	UA9FJB	UA9FJB	7590360200	F402009036
76050327	3	18	1 19/32	5233850	UA9CLB	UA9CLB	7590180300	F403009018
76050328		24		5233837	UA9DLB	UA9DLB	7590240300	F403009024
76050330		36		5233930	UA9FLB	UA9FLB	7590360300	F403009036
76050340	4	36	1 3/4	5233842	UA9FNB	UA9FNB	7590360400	F404009036
76050360	6	48	2 1/8	5233816	UA9HRB	UA9HRB	7590480600	F406009048

Rev. 04-12-11 DH "Deleted 1 1/2 , 2 1/2 , and 5" dia; Changed PW Pipe to JM Eagle; Added Prime and Ridgeline."
 Rev. 03-13-02 AL "Changed from Plain End to Belled End; Changed Mfg. catalog numbers; reformatted page."
 Rev. 01-15-01 MHS "Removed changed some 18" radius to 24" changed Cat. #'s to new and removed some vendors."
 Rev. 12-15-89 GW "First Edition."

PUBLIC UTILITY DISTRICT #2 OF GRANT COUNTY	Date	12/15/89	ELBOW, SCHEDULE 40 PVC, 90 DEGREE				ASSEMBLY UNIT		Yes
	Rev #	4					TDSI		X
	Designer	GW							
	Standards Engineer	Al Silva							
76050307									

CONDUIT, HEAVY WALL RIGID PVC SCHEDULE 40



GENERAL: Rigid schedule 40 PVC (polyvinyl chloride) conduit acceptable for all underground, encased and above-ground applications.

SPECIFICATIONS: The conduit shall be made of heavy wall schedule 40 PVC that is sunlight and impact resistant. The PVC pipe shall meet or exceed the following standards and tests: NEMA standard TC-2 except for bell dimensions, ASTM Test Method D 1598 for Dimensional Requirements, and ASTM D-1785 & /ASTM D-2672 for Joint Specifications. Each section shall have one socket bell end. The socket bell end shall be minimum length as stated per item. Manufacture name, schedule 40, plant identification and date of manufacture shall be stamped or printed on each stick. These marks shall be legible and permanent.

PURCHASING: UOM: Feet
Order 10' foot sections with one socket bell end of appropriate length only. Solid wall only.
Include stock page with each purchase request and bid contract.

STOCK NUMBER	CONDUIT SIZE	Dimensions (inches) Min.			# of 10ft sticks per Bundle or Crate	Socket Bell Min. Length (inch)	Feet per Bundle or Crate	APPROVED MANUFACTURERS & CATALOG NUMBERS			
		O.D.	I.D.	Thickness				PRIME	JM EAGLE	CANTEX	RIDGELINE
76010707	¾	1.05	0.824	0.113	10	1.75	100	49007-010	.75 S40 UL LB	A52AG12	4007510
76010710	1	1.315	1.049	0.113	10	2.00	100	49008-010	1 S40 UL LB	A52BA12	4010010
76010720	2	2.375	2.067	0.154	140	3.00	1,400	49011-010	2 S40 UL LB	A52CA12	4020010
76010730	3	3.5	3.068	0.216	88	3.75	880	49013-010	3 S40 UL LB	A52DA12	4030010
76010740	4	4.5	4.026	0.237	57	4.50	570	49015-010	4 S40 UL LB	A52EA12	4040010
76010760	6	6.625	6.065	0.280	26	6.125	260	49017-010	6 S40 UL LB	A52GA12	4060010

Rev. 03-09-11 DH "Deleted 1 1/2" conduit."

Rev. 07-28-10 DH "Changed Carlon to Prime and PW Eagle to JM Eagle; Updated JM Eagle catalog numbers."

Rev. 07-15-10 DH "Corrected UOM listed; Updated Carlon and PW Eagle catalog numbers;

Rev. 06-18-09 MHS "Converted Page, Deleted foam core specifications; added Ridgline; changed Cat #s"

PUBLIC UTILITY DISTRICT #2 OF GRANT COUNTY	Date	01-24-94	CONDUIT, HEAVY WALL RIGID PVC SCHEDULE 40	ASSEMBLY UNIT		Yes		
	Rev #	9						
	Designer	HC		TDSI	X	TTNI	TMNI	TSNI
	Standards Engineer	AL SILVA		76010707				

CONDUIT, FIBER OPTIC, SCHEDULE 40



GENERAL: Heavy wall rigid PVC Schedule 40 conduit for installation of fiber optic cables.

SPECIFICATIONS: The conduit shall be PVC (polyvinyl chloride) that is a orange color through the entire depth of material. The orange color shall be sunlight resist per UL requirements. The conduit shall be manufactured with one integral solvent-well bell end per length. The conduit shall comply with NEMA TC-2, UL-651, ASTM Test Method D 1598, dimensional requirements of ASTM D-1785 and the joint specifications of ASTM D 2672-96a.

PURCHASING: Quantity "feet". Conduit shall be purchased in 10' lengths.

STOCK NUMBER	SIZE (INCHES)	Average O.D (INCHES)	Approx. I.D (INCHES)	Min. WALL THICKNESS (INCHES)	APPROVED MANUFACTURERS & CATALOG NUMBERS		
					ROYAL PIPE	JM EAGLE	RIDGELINE
76010310	1	1.315	1.033	0.133	1464675	1S40ULORGP	4210010
76010320	2	2.375	2.049	0.154	1464683	2S40ULORGP	4220010

Rev. 11-18-09 DH "Removed "comm' only" print spec; Updated cat. numbers; Changed PW Pipe to JM Eagle; Added Ridgeline."
 Rev. 09-27-02 EA "Added 1" size; changed page number."
 Rev. 08-07-02 APL "Changed CED to Royal Pipe."
 Rev. 03-14-02 MHS "Added warning print 'For communication cable only"

PUBLIC UTILITY DISTRICT #2 OF GRANT COUNTY	Date	08/12/00	CONDUIT, FIBER OPTIC, SCHEDULE 40	ASSEMBLY UNIT		Yes	
	Rev #	6		SUBSTITUTIONS		Approval Required	
	Designer	MHS		TDSI	TTNI	TMNI	TSNI
	Standards Engineer			76010310			

BUS, JUNCTION, LOADBREAK, 15 kV, 200 AMP

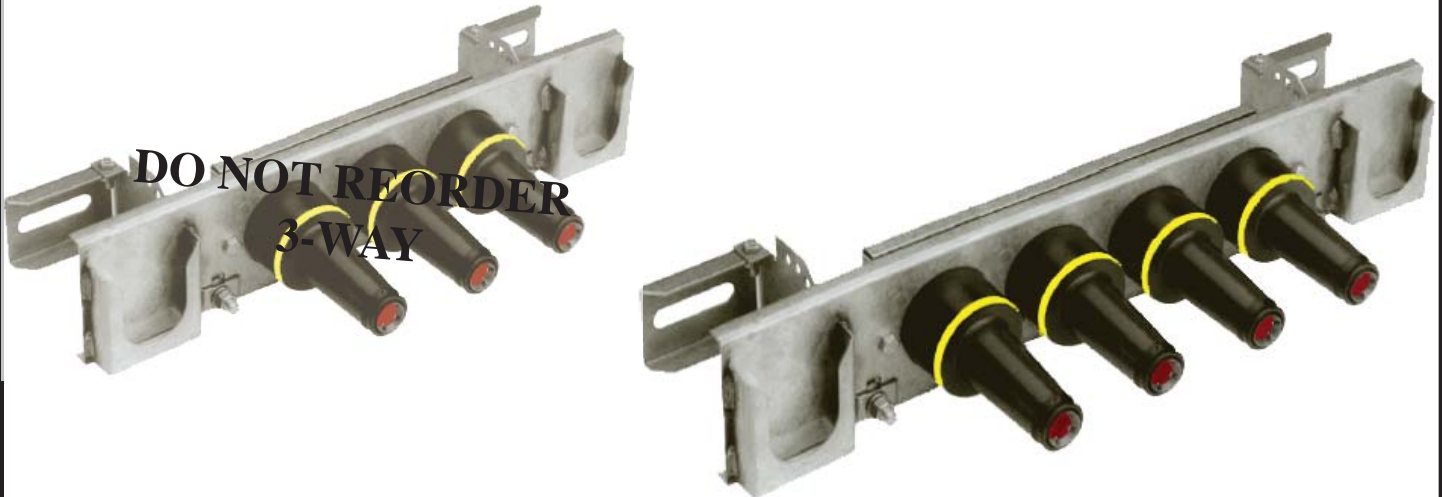

GENERAL: 200 amp loadbreak junction complete with grounding nuts and variable-tilt mounting angle stainless steel bracket.

SPECIFICATIONS: The Junction shall meet all requirements of IEEE Standard 386-*Separable Insulated Connector Systems*. The bracket shall have a parking stand on each side of the bushing arrangement. The frontplate and parking stand shall be made of 16 gauge grade 302 or 304 stainless steel. The loadbreak junction shall have a solid current path of copper alloy with no aluminum components. The junction bushings shall have a fault activated piston that is forced forward by gas pressure during fault closing. The bushings shall have a rubber-insulated, semi-conductive shield and a bright yellow latch indicator ring located on the circumference of the interface collar. The junction shall have a 13 gauge grade 302 or 304 stainless steel bracket that is adjustable up to 90° tilt in 10° increments. The bracket shall be factory assembled onto the junction in an outer position on a 45° angle from horizontal. The junction shall have two ½” threaded hex nuts, referred to as grounding nuts, welded on the underside of the base plate to accommodate a T-bolt ground lug connector (not included).

RATINGS:

Max. Operations:	10 at 10,000 amps symmetrical
Short time:	10,000 for 0.17 sec. symmetrical.
Phase to Phase Max:	14.4 kV
60 Hertz (1 min.):	34 kV rms
	Phase to Ground Max: 8.3 kV
	BIL 95 kV

PURCHASING: UOM: Each
 The following items shall be included in kit form with each junction:
 Loadbreak junction, Shipping caps/dust shield, Silicone Lubricant, and Installation instructions.
Include stock page with each purchase request and contract document.

STOCK NUMBER	BUSHINGS	APPROVED MANUFACTURERS & CATALOG NUMBERS
		COOPER
66940003	3	DO NOT REORDER
66940005	4	LJ215C4B-0036

Rev. 06-10-14 DH "Removed Hubbell as approved; Updated photo."
 Rev. 02-03-12 DH "Removed Elastimold as approved; Updated Cooper catalog number; Label 3-way as DO NOT REORDER."
 Rev. 08-14-09 DH "Added Hubbell as approved; Updated Cooper catalog number to add ground nut."
 Rev. 05-08-06 DH "Updated 'T&B' catalog number; Reworded 'general' and 'specification' statements; Converted page in InDesign."

PUBLIC UTILITY DISTRICT #2 OF GRANT COUNTY	Date	12/15/76	BUS, JUNCTION, LOADBREAK, 15 kV, 200 AMP	ASSEMBLY UNIT		Yes	
	Rev #	8					
	Designer	GH		FDSI X	TTNI	TMNI	TSNI
	Standards Engineer	A. SILVA		66940003			

200 AMP PROTECTIVE CAP, 15kV

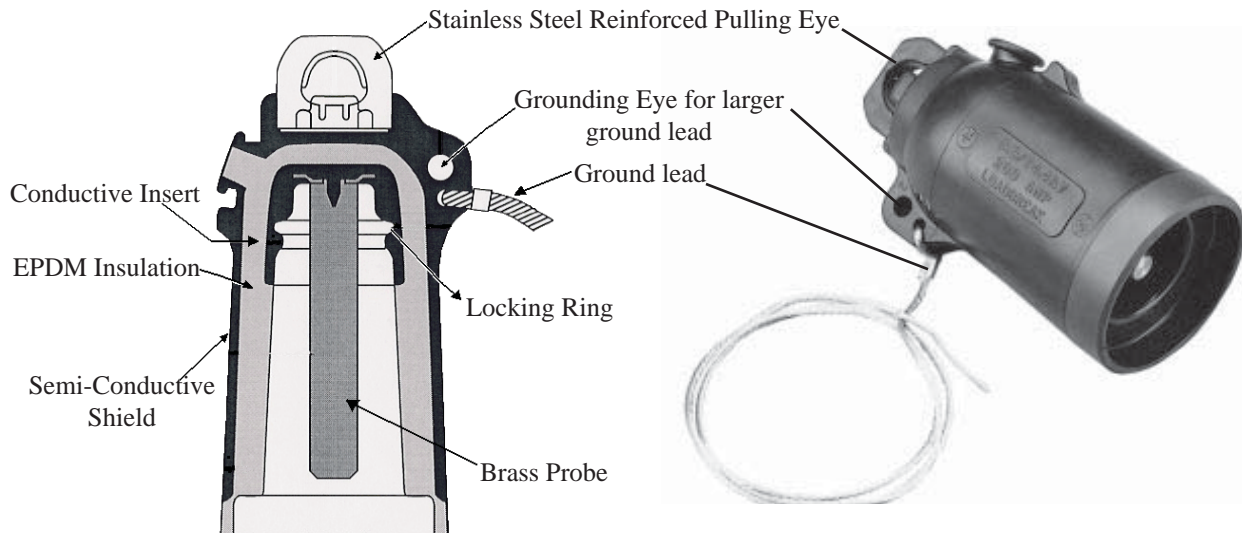

CUT A-WAY VIEW OF CAP

GENERAL: 200 amp protective cap for installation on 15kV load break bushings.

SPECIFICATIONS: Cap shall meet or exceed the requirements of ANSI/IEEE Standard 386. Cap shall be constructed to mechanically seal loadbreak bushing interfaces. Unit shall have brass probe with concentric locking ring, bedded in a conductive insert, EPDM insulation with a semi-conductive shield, in compliance with ANSI/IEEE Standard 592, a stainless steel reinforced pulling eye, grounding eye and a minimum 36" 14 AWG braided lead for grounding to avoid low energy discharge.

RATING: 200 amp.

RATING TABLE (kV)			
PHASE TO PHASE MAX	PHASE TO GROUND MAX	60 Hz 1 MINUTE WITHSTAND	BIL
14.4	8.3	34	95

PURCHASING: The following items shall be included in kit form with each Cap:
 Protective strap with stranded copper ground wire
 Silicone Lubricant
 Installation Instruction sheet

STOCK NUMBER	VOLTAGE CLASS	APPROVED MANUFACTURERS & CATALOG NUMBERS		
		COOPER	ELASTIMOLD	HUBBELL
66945044	15	LPC215	160DRG	215ICI

Rev. 05-02-06 DH "Updated 'Hubbell' catalog number; converted page in InDesign."
 Rev. 07-08-04 MRS "Updated page format; added 'T&B/Elastimold' and Hubbel/Chardon."
 Rev. 07-26-00 MHS."Removed Blackburn, changed names and catalog numbers"
 Rev. 01-25-97 L.L. "Added Chardon and removed Joslyn as approved."

PUBLIC UTILITY DISTRICT #2 OF GRANT COUNTY	Date	03/15/91	200 AMP PROTECTIVE CAP, 15kV	ASSEMBLY UNIT		Yes		
	Rev #	5 +		SOLE SOURCE		No		
	Designer	MHS		TDSI	X	TTNI	TMNI	TSNI
	Standards Engineer	E. WENKE		66945044				

CONNECTOR, LOADBREAK, ELBOW, 15kV, 200A, TEST POINT



Cooper Power Systems
"elbow" with Test Point
and Cap.



Elastimold "elbow" with
Test Point & Cap.

GENERAL: 200 amp loadbreak elbow connector for underground cable connection to apparatus.

SPECIFICATIONS: Load break separable connector shall meet or exceed the requirements of ANSI/IEEE Standard 386 for *Separable Insulator Connection Systems*. Load break separable connectors shall be fully shielded and submersible. Units shall be molded from EPDM rubber and have semi-conducting insert and shield. Load break separable connectors shall include a capacitive test point on the molded body with snap-on cap. Each elbow connector kit shall include the elbow, a copper-top compression connector, probe installation tool, loadbreak probe, silicone lubricant, and instructions.

RATINGS:	BIL	95	Corona Level Min.	11 kV	
	60 Hz 1 min withstand			34	
	Phase to Ground Max.			8.3 kV	
	Phase to Phase Max.			14.4 kV	
	Operational Ratings		Operations at 10,000 symmetrical amps		10
	Short circuit Ratings		At 10,000 symmetrical amps		0.17 Sec.

PURCHASING: UOM: Each Standard Packaging: 20/pk
Each elbow kit shall be packaged and shipped in a sealed plastic bag.

STOCK NUMBER	Conductor Size	Conductor	APPROVED MANUFACTURERS & CATALOG NUMBERS	
			Cooper Power Systems	Elastimold
66930352	#2	Stranded Aluminum Full Neutral	LE215AB04T	166LR-B-5220
66930452	1/0		LE215CC06T	166LR-B-5240
66930652	4/0		LE215DD09T	166LR-C-5270

Rev. 10-02-13 DH "Changed Cooper catalog on 1/0 & 4/0 to increase cable range."
 Rev. 02-28-13 DH "Updated Cooper catalog number for bulk packaging."
 Rev. 03-19-10 MHS "Updated Cooper Cat #,s formatted as standard, change specifications for separable connectors."
 Rev. 09-08-04 DH "Updated photo on Page 2 of 2, reworded rating table."

PUBLIC UTILITY DISTRICT #2 OF GRANT COUNTY	Date	05/02/95	CONNECTOR, LOADBREAK, ELBOW, 15kV, 200A, TEST POINT	ASSEMBLY UNIT		Yes	
	Rev #	8					
	Designer	LL		FDSI X	TTNI	TMNI	TSNI
	Standards Engineer	A SILVA		66930352			

CONNECTOR, LOADBREAK, ELBOW, 15kV, 200A, TEST POINT

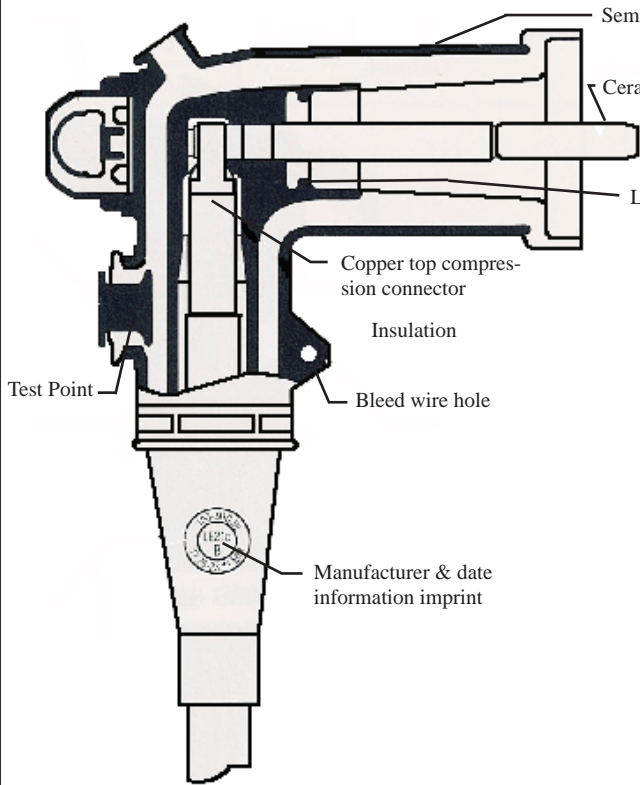

Cooper Power System
Cutaway Drawing

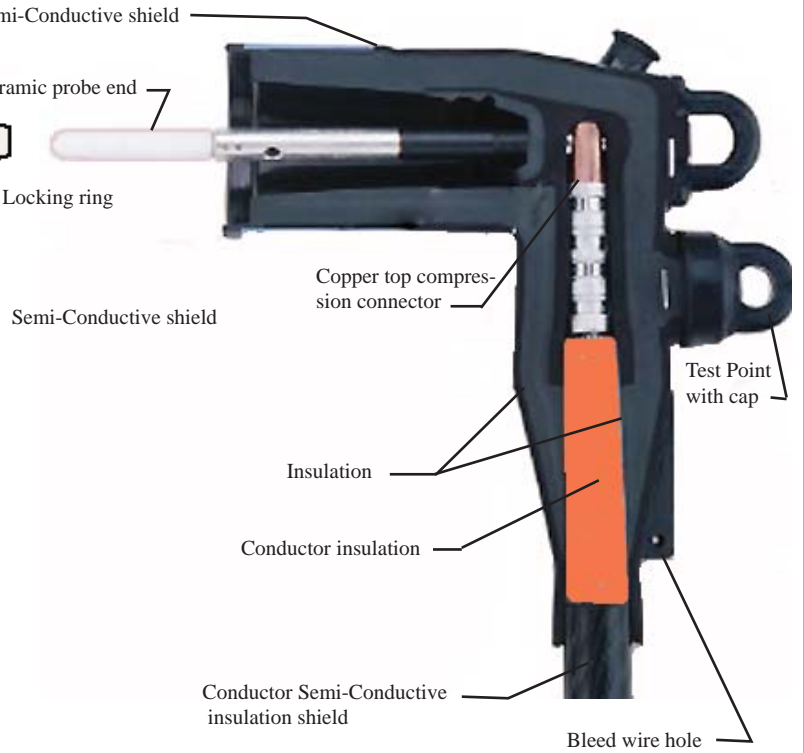

Elastimold Cutaway Model.

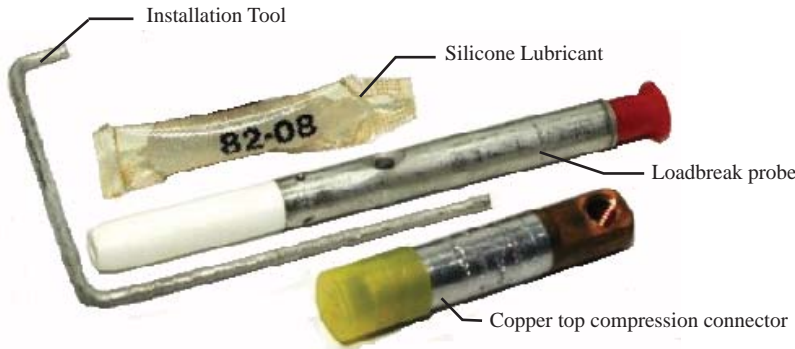

Kit to be included with each elbow.

PUBLIC UTILITY DISTRICT #2 OF GRANT COUNTY	Date	05/02/95	CONNECTOR, LOADBREAK, ELBOW, 15kV, 200A, TEST POINT				ASSEMBLY UNIT		Yes
	Rev #	8					TDSI		X
	Designer	LL	Standards Engineer		66930352				
	A SILVA								

POLES, STREET LIGHT, STEEL, DIRECT BURIAL

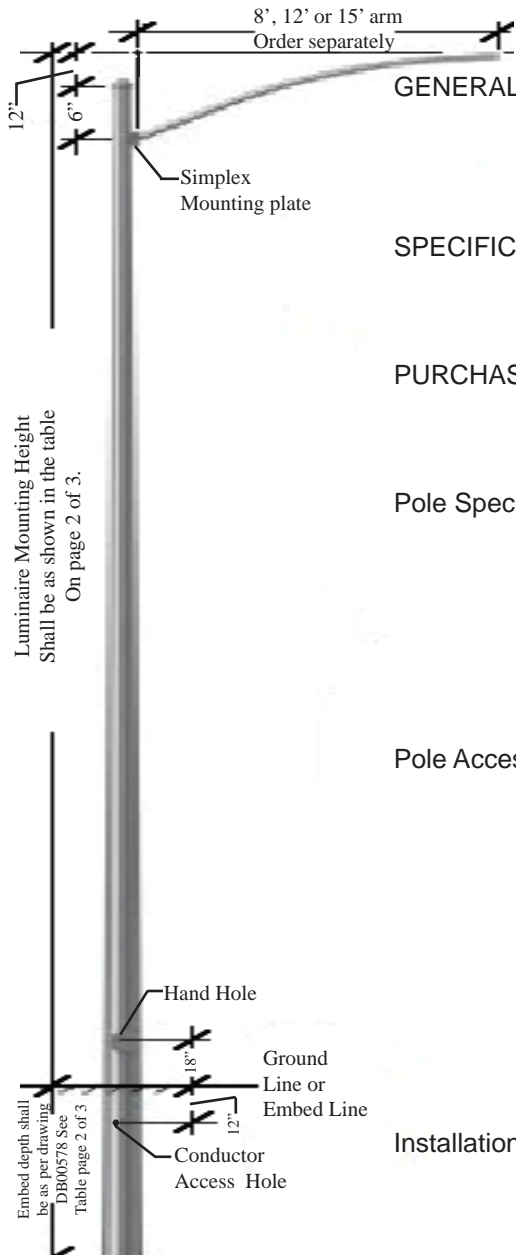

GENERAL: Embedded steel street light pole with tri-bolt simplex luminaire arm mounting system. To be ordered without arms. Arms shall be ordered as follows: Stock Page # 49001108 for all arms in 8', 12' and 15' lengths.

SPECIFICATIONS: Poles shall be manufactured in accordance with drawing #DB00578 from Valmont and noted on this stock page. See drawing for EMBEDDED POLES.

PURCHASING: Order each Pole only on this stock page. **Each order is to be verified by Blankenship and Associates. Include stock page with order.**

Pole Specifications: Pole shaft and simplex mounting brackets shall be Grade A steel as per ASTM A 595. Pole body shall be constructed of 11 gauge steel with a 0.11 nominal thickness in a single piece. Pole shall be constructed of one piece rolled steel with a full longitudinal high frequency electric resistance seam weld. Pole body shall have a uniform taper from base to top of 0.14 inches per foot.

Pole Accessories: Each pole shall have the following accessories included:
 1. Design criteria see page 3 of 3.
 2. Pole Simplex mounting base. (Detail on page 3 of 3)
 3. Reinforced handhole with cover. Cover shall be included with the pole, and have a ground screw inside the pole next to the handhole. (Detail on page 2 of 3)
 4. Pole cap assembled on pole at the factory. (Detail on page 2 of 3)
 5. 1 - 5/8" Conductor access hole 12" below the ground line.
 6 & 7. Finish requirements on page 3 of 3.

Installation: Poles shall be embedded as shown in the pole dimension table on page 2 of 3.

STOCK NUMBER	Item Description	District Height Designation	APPROVED MANUFACTURERS & CATALOG NUMBERS
			Valmont
49001130	Embedded Steel Pole	30'	EM 32-870A 336 OS GV HH AH
49001140		40'	EM 32-E00B460 OS GV HH AH

Catalog number is as follows EM 32 = Pole type. Next 4 Digits = Base Dia. Next 3 digits = height (336 = 33 feet 6 inches) OS = without arms. GV = galvanized finish. HH = Handhole. AH = 1 - 5/8" Conductor access hole..

- Rev. 07-24-12 MHS "Changed specifications and accessories list."
- Rev. 02-20-02 AS "Added AH note to Valmont Catalog number."
- Rev. 08-29-00 MHS "Changed stock page/stock # and added item 49007140."
- Rev. 08-22-00 AS "Change in Valmont Cat. #."

PUBLIC UTILITY DISTRICT #2 OF GRANT COUNTY	Date	06/13/00	POLES, STREET LIGHT, STEEL, DIRECT BURIAL	ASSEMBLY UNIT		Yes	
	Rev #	5					
	Designer	MHS		TDSI	TTNI	TMNI	TSNI
	Standards Engineer	E WENKE		X			
				49001130			

POLES, STREET LIGHT, STEEL, DIRECT BURIAL

Pole dimension table.

STOCK NUMBER	Pole Base OD (inches)	Pole Top OD (inches)	Pole Length (feet & inches)	Pole Embed Depth (feet & inches)	Pole OD @ Grade (inches)
49001130	8.7	4.01	33' 6"	5' 6"	7.93
49001140	11	4.56	46	6' 6"	10.09

Luminaire Mounting Dimensions.

STOCK NUMBER	Arm Length (feet)	Arm Rise above Simplex (inches)	Simplex Height (feet & inches)	Luminaire Height (feet & inches)
49001130	8	22	27' 6"	29' 4"
	12	30		30' 0"
	15	36		30' 6"
49001140	8	22	39' 0"	40' 10"
	12	30		41' 6"
	15	36		42' 0"

Items below are on drawing #DB00578 Details See Detail # 3 for POLE TOP CAP, #5 for HANDHOLE . See Detail RADIAL INDEX-EMBEDDED POLES on the drawing.

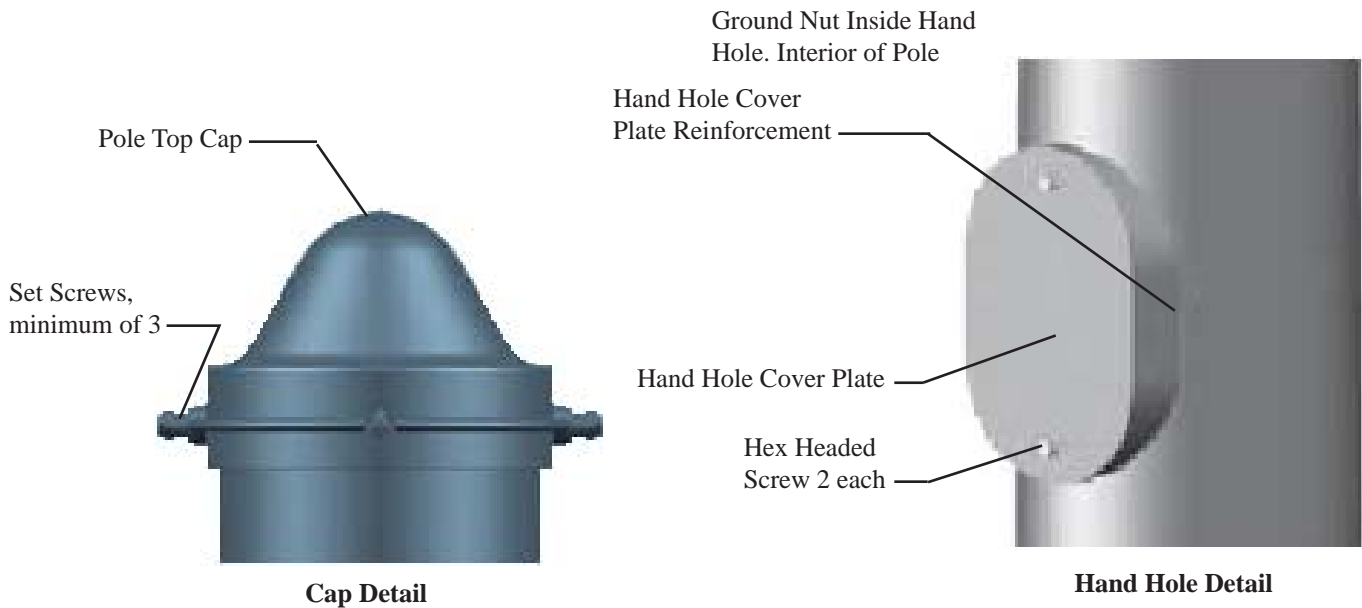

PUBLIC UTILITY DISTRICT #2 OF GRANT COUNTY	Date	06/13/00	POLES, STREET LIGHT, STEEL, DIRECT BURIAL	ASSEMBLY UNIT		Yes	
	Rev #	5					
	Designer	MHS		TDSI X	TTNI	TMNI	TSNI
	Standards Engineer			49001130			
		E WENKE					

POLES, STREET LIGHT, STEEL, DIRECT BURIAL

Specifications continued from page 1 of 3:

DESIGN CRITERIA: These specifications shall produce a standard pole that shall withstand dead loading factors of the arm and luminaire and theoretical dynamic loads imposed by 100 mile per hour winds with a 1.3 gust factor on the pole fully assembled and installed with 15 foot arms with luminaires with a minimum of 0.5 ice loads.

- A. Height correction factors and drag coefficients shall be applied to the entire structure with appropriated safety factors.
- B. Poles shall be manufactured in accordance with Drawing # DB00578 from Valmont.

POLE SIMPLEX MOUNTING BASE: Base & base mounting bracket shall be hot rolled steel conforming to ASTM A 36. Both the base and the base bracket shall be full filet welded to the pole. The weld shall be cleaned, ground smooth prior to finishing the pole. (Detail #4 Drawing DB00578)

The Simplex base shall have 3 (three) drilled and tapped holes for 3/4" bolts. These holes shall be free of debris finish or tap residues. Note: Bolts shall be included with the arms not the poles.

REINFORCED HANDHOLE: Each pole shall have a 4" X 6.5" handhole cut as shown and centered 1' 6" above the ground line. Handhole shall be 90° clockwise to the luminaire arm/s. This hand hole shall be reinforced with 11 gauge steel welded to the pole and the weld shall be clean, ground and brushed prior to finish. Each pole shall be equipped with an 11 gauge steel handhole cover that mounts with two hex head bolts, one at the top of the hand hole and one at the bottom. Cover plate shall have sharp edges removed and have a galvanized finish. (Detail #5 Drawing DB00578)

A ground nut shall be welded inside the handhole. The nut shall be 1/2" 13 UNC hex nut with hex head bolt to ground the pole. (Detail #5 Drawing DB00578)

POLE CAP: Each pole shall be equipped with a removable cap as shown constructed of 11 gauge steel and galvanized finish. Cap shall be installed at the factory with a minimum of three set screws. (Detail #3 Drawing DB00578)

CONDUCTOR ACCESS: Each pole shall have a hole drilled 12" below the embed line.. The hole shall be 1-5/8" in diameter directly below the Hand Hole. (Detail RADIAL INDEX-EMBEDDED POLES Drawing DB00578)

FINISH CLEANING AND PRIMING: After cleaning (Sand blast where required to remove corrosion or scale) and removal of burs, slag, metal and nonmetallic foreign materials the formed and shaped pole is to be immersed in an agitated 4.5% to 6% concentrated caustic solution with a temperature range of 150° to 180° F. This procedure is to be followed by immersion in a sulfuric acid solution of not less than 10% or more than 12% concentration within a temperature range of 150° to 160° F. Deep rinse in a fully submerged fresh water bath. After completely drying, the poles shall be immersed in a concentrated zinc ammoniumchloride flux solution heated to 170° F. The acidity of the flux solution shall be between 4.5 and 5.0 pH.

GALVANIZED FINISH: The pole shall be finished with a hot-dip method as required by ASTM 123 (Fabricated Products). Hardware items will be finished with a hot-dip method as required by ASTM F2329. Both shall be by immersion in a molten bath of prime grade zinc maintained at a temperature range of 810° to 850° F. Restrict aluminum content of the bath to less than 0.01% and skim the surface prior to immersion and removal. If the finish is contaminated by slag or flux ash the pole shall be refinished by repeating the cleaning and priming steps prior to reemerging in the molten bath.

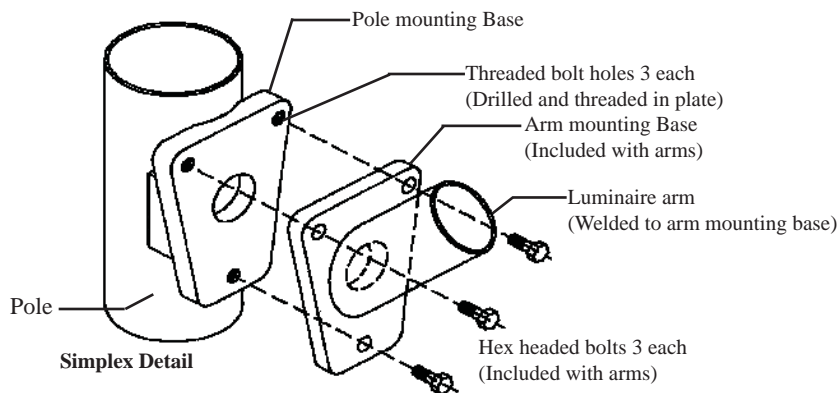

PUBLIC UTILITY DISTRICT #2 OF GRANT COUNTY	Date	06/13/00	POLES, STREET LIGHT, STEEL, DIRECT BURIAL	ASSEMBLY UNIT		Yes		
	Rev #	5						
	Designer	MHS		TDSI	X	TTNI	TMNI	TSNI
	Standards Engineer	E WENKE		49001130				

PEDESTAL, SECONDARY, ABOVE GROUND

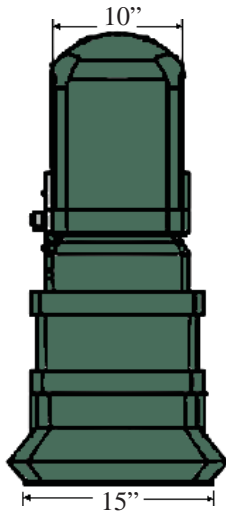

Side View



Front View with cover



Front View without cover



Enlarged view of 6-way 350 MCM Lay-in connector

GENERAL:

Underground-fed enclosure pedestal with connectors for secondary connections from transformers.

SPECIFICATIONS:

The pedestal shall be made with UV stabilized polyethylene. The pedestal shall have a flared base and step design to resist deflection when buried. The words "GROUND LINE" or "GRADE LINE" shall be molded into the front and back of the pedestal or molded on each side. The word "ELECTRIC" shall be molded into the top of the cover. The pedestal shall be provided with penta bolt lock and provisions for ring lock for ANSI type double-locking system consisting of captive penta head bolt recessed into blind hole. The penta head bolt shall be sized to fit a Snap-on socket head #B2191. All locking hardware shall be stainless steel.

Three 6-way 350 MCM lay-in connectors shall be installed in each pedestal. The connectors shall include clear lexan or plastic covers. The connectors shall be fabricated from 6061-T6 aluminum alloy and shall be compatible with both copper and aluminum conductor. All connectors shall conform to ANSI 119.4 Class A conductors.

LABELS:

The warning label shall be supplied by the District, Stock Number 58080555. The label shall be in both English & Spanish. The label shall be 7" x 11. After award of the contract, the District shall ship the required number of labels plus 10% extra. The manufacturer may request additional labels at an extra charge.

PURCHASING:

Quantity "Each". Standard package is 100 each.

STOCK NUMBER	COLOR	SUGGESTED BURIAL DEPTH	APPROVED MANUFACTURERS & CATALOG NUMBERS		
			CMC / ESP	COLUMBIA	NORDIC
44402439	MUNSEL GREEN	16"	PF3-L1350-6IG	PF300C1G-MG188	PSPF-101538-MG-L6350-GRANT

Rev. 03-11-09 DH "Updated Columbia cat. number; Corrected measurements in photo; Corrected referenced label stock number."
 Rev. 09-08-05 DH "Changed specs to 'District supplying labels'; Added photo of decal to drawing."
 Rev. 04-19-01 MHS "Change catalog number for Columbia & CMC/ESP."
 Rev. 03-20-01 MHS "Change catalog number for Columbia; Added Nordic; Removed stake."

PUBLIC UTILITY DISTRICT #2 OF GRANT COUNTY	Date	08/14/96	PEDESTAL, SECONDARY, ABOVE GROUND		ASSEMBLY UNIT		Yes		
	Rev #	5			SUBSTITUTIONS		Approval Required		
	Designer	MHS			TDSI	X	TTNI	TMNI	TSNI
	Standards Engineer				44402439				
E. WENKE									

COVER, 4'8" x 4'8", 15 kVA - 167 kVA TRANSFORMER

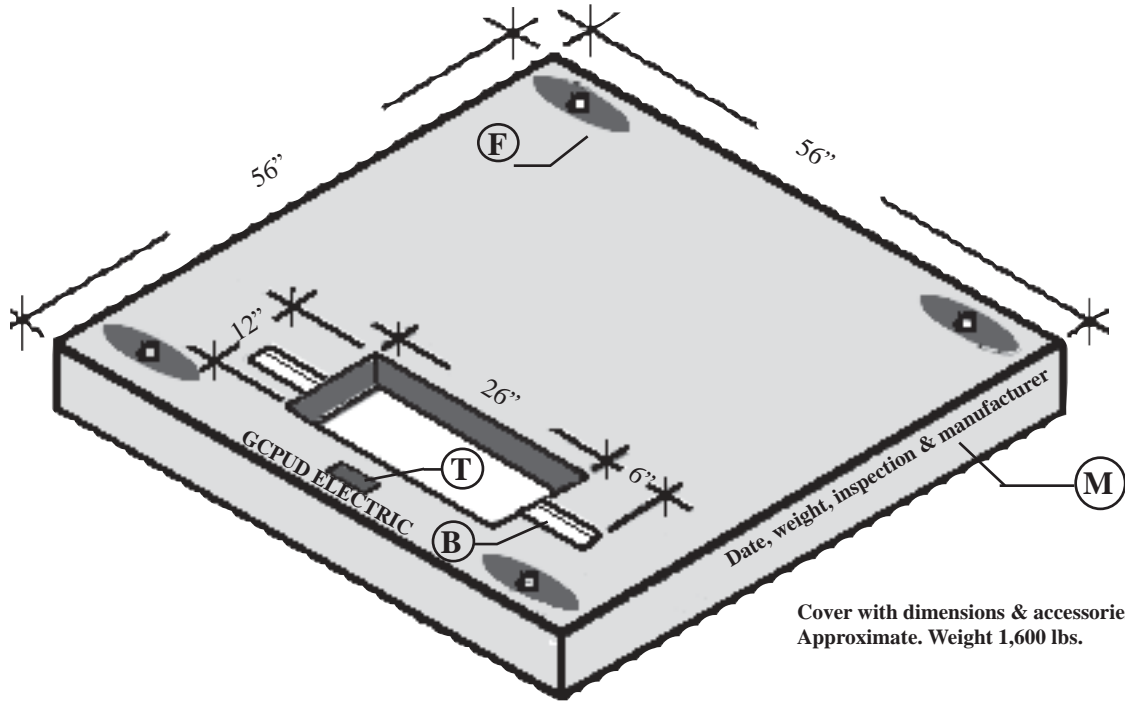

Cover with dimensions & accessories.
Approximate. Weight 1,600 lbs.

GENERAL: Cover for 1 phase (15 kVA - 167 kVA) pad mount transformer.

SPECIFICATIONS: Concrete cover shall be constructed per the Districts Precast Concrete Product Specification #03800: ~~S: \DATA\STANDARD\~~**Product Specifications/ 03800 Precast Concrete Products.** The cover must support at least 3,000 lbs. The cover the words "GCPUD ELECTRIC" on the front as shown.

B. Galvanized C Channel 6" long 1-½ X 1-½ X 12" One (1) on each side of the slot. 2 each cover.

F. Burke's Lifting Eye (4) in each corner on the cover. 8 each vault and cover. Size as required for lifting load.

M. Date, Weight and Inspection Stamp Paper or plastic tags shall not be accepted.

T. Vault Tag Impression - 5 1/2" X 2" Impression centered as shown. One each.

PURCHASING: Include stock page with each purchase request or contract bid document.
See stock page #22022374 for vault.

OFF-LOADING: Any units with pallets that are oversized, undersized, damaged, broken, have loose boards, or protruding nails or screws shall not be accepted.

STOCK NUMBER	AU	SIZE		APPROVED MANUFACTURERS & CATALOG NUMBERS	
		L	W	UTILITY VAULT COMPANY	H-2 PRECAST
22412478	U46V	4' 8"	4' 8"	504 PAD SPECIAL	TPG550-1226

Rev. 10-04-12 MHS " Added item "T" Tag Impression Note, change title to "Cover"."
 Rev. 04-12-11 MHS "Updated Specifications and Page."
 Rev. 05-06-09 DH "Updated H2 catalog number; Added stock page and specifications inclusion note."
 Rev. 09-15-06 DH "Added Burke's lifting eyes to specs; reformatted page in InDesign."

PUBLIC UTILITY DISTRICT #2 OF GRANT COUNTY	Date	12/05/89	COVER, 4'8" x 4'8", 15 kVA - 167 kVA TRANSFORMER	ASSEMBLY UNIT		Yes	
	Rev #	8					
	Designer	GW		TDSI	TTNI	TMNI	TSNI
	Standards Engineer	AL SILVA				22412478	

FAULT INDICATORS - UNDERGROUND TEST POINT RESET

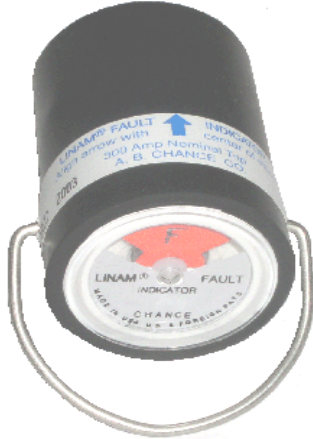

Photo of E.O. Schweitzer Fault Indicator..



Photo of Cooper Fault Indicator.

General: Fault indicators for both 200 & 600 Amp circuits.

Rating: Rated for 15kV systems.
 Power Requirements 5 kV Minimum
 Continuous Current 125% of Trip Current Max.
 Maximum Fault Current 20,000 for 10 Cycles
 Reset Time 3 Min. @ 5 kV @ 25° C automatic at minimum voltage.

Specifications: Indicators shall be fabricated of conductive EPDM rubber, epoxy encapsulated electronic componentry and shall be suitable for submersible application. Indicators shall be fabricated and tested per ANSI/IEEE 495 latest edition. Indicators shall be mountable on both Elastimold and Cooper elbows. Adapter kits, when required, for mounting shall be included with the indicator.

Purchasing: Order each including adaptor kits for Cooper and Elastimold elbows in the 200 and 600 amp configuration. See stock #23154004 for adaptor kits.

STOCK NUMBER	TRIP AMPS	CIRCUIT AMPS	APPROVED MANUFACTURERS & CATALOG NUMBER	
			RTE Cooper	E.O. Schweitzer
23151130	400	200	STLO	1TPRI0400B
23151180	800	600	STHI	1TPRI0800B

Option "B" includes bailing ring

Rev. 02-01-05 MHS " Deleted 23151140, 1150, 1170 & 1190 changed specifications and photos."
 Rev. 06-03-98 M.B. "Deleted RTE Cooper Prod. No.-Changed RTE Cooper Catalog No."
 Rev. 04-24-97 "Updated ABChance/Hubbell numbers.
 Rev. 08-22-95 "Removed Adapter Information - reassign adapter to #23154000.

PUBLIC UTILITY DISTRICT NO. 2 OF GRANT, COUNTY WASHINGTON

FAULT INDICATORS - UNDERGROUND

DATE:	09/10/87	STOCK CATALOG	<input checked="" type="checkbox"/> TDSI	23151130
DESIGNER;	LL		<input type="checkbox"/> TIN1	
STANDARDS ENGR;	A. Silva		<input type="checkbox"/> TMNI	
			<input type="checkbox"/> TSNI	Page 1 of 1

ENCLOSURE, LIGHTING JUNCTION BOX

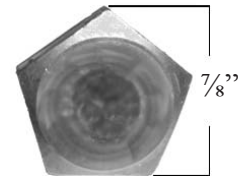
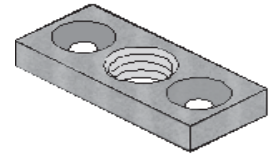
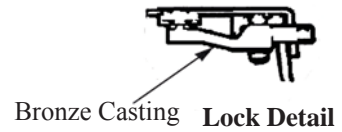

Head Dimensions of Penta Bolt

- GENERAL:** Lighting junction box with reinforcing ribs and cover with recessed penta-head locking bolt.
- SPECIFICATIONS:** Enclosure shall be molded of green high density polyethelene with a min. thickness of 5/16". Cover shall be made of high density polyethylene. The word "ELECTRIC" shall be molded into the cover. The text shall be at least 1" tall.
- RATING:** **Only use in non-vehicular traffic situations. Not recommended for use in concrete or asphalt.**
- SIZE:** Exterior dimensions of the base must be a minimum of 15 1/4" x 20 1/2" x 12" high.
- PURCHASING:** UOM: Each
Each unit shall include cover and penta head locking bolt.
Enclosure must include 1/2" Penta-head bolts with 7/8" heads.

STOCK NUMBER	TYPE	APPROVED MANUFACTURERS & CATALOG NUMBERS		
		CARSON INDUSTRIES	PENCELL / HUBBELL	APPLIED ENG.
22097799	LIGHTING	1419-12-4+large penta-GE	PE14HDX005P3	1015T-1G2G-penta

Rev. 01-19-16 DH "Updated Pencil catalog number to Hubbell reference number
 Rev. 11-19-13 DH "Removed requirement for "electric" in two places."
 Rev. 09-15-08 DH "Updated Carson Ind. and Applied Eng. catalog numbers for penta head requirement."
 Rev. 12-22-05 DH "Added Penta Bolt Head dimension requirements; updated 'Carson' catalog number."

PUBLIC UTILITY DISTRICT #2 OF GRANT COUNTY	Date	03/24/87	ENCLOSURE, LIGHTING BOX	ASSEMBLY UNIT		Yes		
	Rev #	7						
	Designer	RS		TDSI	X	TTNI	TMNI	TSNI
	Standards Engineer	AL SILVA		22097799				

COVER, 6'2" x 5'0", 45 kVA - 500 kVA TRANSFORMER

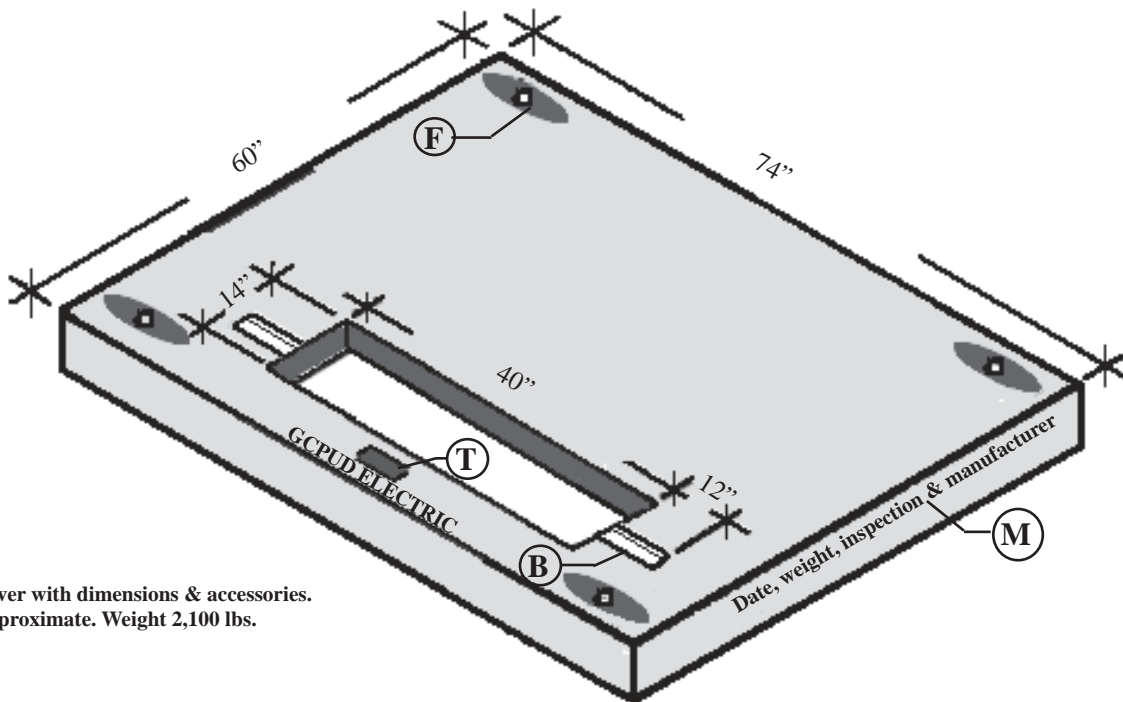

Cover with dimensions & accessories.
Approximate. Weight 2,100 lbs.

GENERAL: Cover for 3 phase (45 kVA - 500 kVA) pad mount transformer vaults.

SPECIFICATIONS: Concrete cover shall be constructed per the Districts Precast Concrete Product Specification #03800: *S:\DATA\STANDARD\Product Specifications\ 03800 Precast Concrete Products*. The cover must support at least 6,500 lbs. The cover the words "GCPUD ELECTRIC" on the front as shown.

B. Galvanized C Channel 6" long 1-1/2 X 1-1/2 X 12" One (1) on each side of the slot. 2 each cover.

F. Burke's Lifting Eye (4) in each corner on the cover. 8 each vault and cover. Size as required for lifting load.

M. Date, Weight and Inspection Stamp Paper or plastic tags shall not be accepted.

T. Vault Tag Impression - 5 1/2" X 2" Impression centered as shown. One each.

PURCHASING: Include stock page with each purchase request or contract bid document.
See stock page #22022374 for vault.

OFF-LOADING: Any units with pallets that are oversized, undersized, damaged, broken, have loose boards, or protruding nails or screws shall not be accepted.

STOCK NUMBER	AU	SIZE		APPROVED MANUFACTURERS & CATALOG NUMBERS	
		L	W	UTILITY VAULT COMPANY	H-2 PRECAST
22402486	U47V	6' 2"	5' 0"	504 PAD SPECIAL drawing #BID-610 sheet 2 with 12" channel	TPG7460-1640

Rev. 10-04-12 MHS " Added item "T" Tag Impression Note Changed title to 'Cover'".
Rev. 04-12-11 MHS "Updated Specifications & Page."
Rev. 05-06-09 DH "Updated H2 catalog number; Added stock page and specifications inclusion note."
Rev. 09-15-06 DH "Added Burke's lifting eyes to specs; reformatted page in InDesign."

PUBLIC UTILITY DISTRICT #2 OF GRANT COUNTY	Date	12/04/89	COVER, 6'2" x 5'0" 45 kVA - 500 kVA TRANSFORMER	ASSEMBLY UNIT		Yes	
	Rev #	7					
	Designer	GW		TDSI	TTNI	TMNI	TSNI
	Standards Engineer	AL SILVA				22402486	

COVER, 4'8" x 4'8"

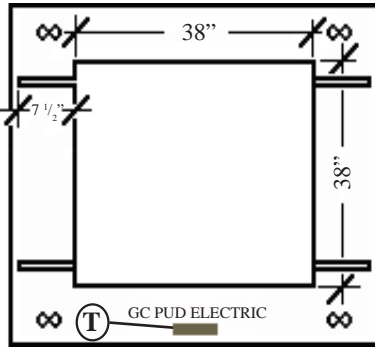

Secondary cabinet cover without hatch

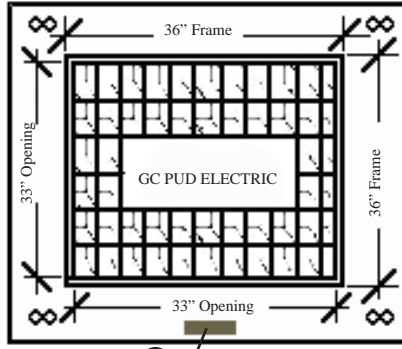

Chevron 36" Square Grate Hatch

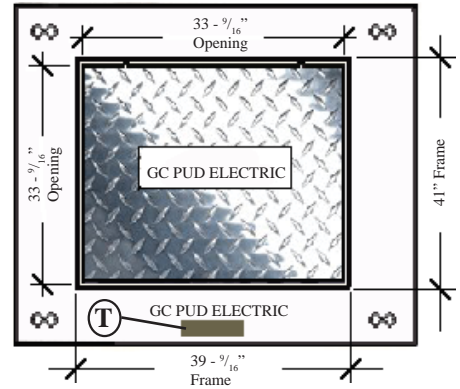

Diamond Plate 36" Square Steel Hatch for Electric

GENERAL: Covers for 4' 8" vaults.

SPECIFICATIONS: Concrete cover constructed per the Districts Precast Concrete Product Specification #03800: *S:\Data\STANDARD\SPECIFICATIONS\District Specs\03800 Precast Concrete Products*. Stock 22142378 & 22152378 covers shall have the words, "**GRANT COUNTY PUD ELECTRIC**" or "**GCPUD ELECTRIC**" and stock 22152379 shall have the words "**GRANT COUNTY PUD FIBER**" or "**GCPUD FIBER**" either welded, imprinted or embossed in the center or along the concrete. On the Secondary cabinet cover 22052078, "GCPUD ELECTRIC" shall be made in the concrete. The cover shall have 4 Burke's lifting eye, one at each corner. The secondary cover shall have four (4) 3/4" unistrut channels 7.5" long poured in the concrete, a minimum of 6" from the corner as shown. Secondary cabinet cover shall have a minimum 38" opening.
T. Vault Tag Impression - 5 1/2" X 2" Impression centered as shown. Total One each cover.

PURCHASING: Quantity "Each"
 Include stock page with each purchase request or contract bid document.
 Fiber vault cover is the same as the electric "Diamond Plate" shown above with fiber instead of Electric on it.

OFF-LOADING: Covers shall be shipped on pallets. Any units with pallets that are oversized, undersized, damaged, broken, have loose boards, or protruding nails or screws shall not be accepted.

STOCK NUMBER	AU #s	TYPE	WEIGHT	APPROVED MANUFACTURERS & CATALOG NUMBERS	
				UTILITY VAULT	H-2 PRECAST
22052078	U50VS	OPEN TOP	979 lbs	55-CAB-GCPUD	TPG550-3838
22142378	-----	LOCK PRESSED GRATE	1045 lbs.	55-332	VLG550-13PL-G
22152378	U54D U54V	DIAMOND PLATE	1031 lbs.	55-332P	VLG550-13PL
22152379	J232	DIAMOND PLATE	1031 lbs.	55-332P-FIBER	VLG550-13PL-FIBER

Rev. 10-04-12 MHS " Added item "T" Tag Impression Note, changed title to 'Cover'."
 Rev. 04-12-11 MHS "Changed hatch specifications to USF Standard added AU #s added 22152379 for Fiber."
 Rev. 05-06-09 DH "Updated H2 catalog number; Added stock page and specifications inclusion note."
 Rev. 10-14-08 DH "Changed size in the title."

PUBLIC UTILITY DISTRICT #2 OF GRANT COUNTY	Date	12/04/01	COVER 4'8" x 4'8"	ASSEMBLY UNIT		Yes		
	Rev #	10						
	Designer	GW		TDSI	X	TTNI	TMNI	TSNI
	Standards Engineer	AL SILVA		22052078				

COVER, 4'8" x 4'8"

Hatch Specification:

The access hatches shall be made by USF Fabrication or equal and be in accordance with drawing #57667 with 1/4" aluminum diamond plate, slamlock with penta head bolt, recessed option for padlock. 180° opening with a lock position at 90°.

Hatches shall have a minimum of 33" (inches) clear opening.

See page 1 of 2 for drawing number with other hatch details.

Grate Specifications

The grate shall be hot dipped galvanized steel with the following minimum characteristics.

Grate shall be lift out without hinges, and shall be provided with penta head lock down bolts and holders on two opposing sides.

Press locked bar grating, also known as dovetailed. Galvanized steel-200 smooth, 2" X 3/16" bearing bars, 1 - 3/16" on center, rectangular cross bars 4" on center.

Grate frames shall be 1-1/2" X 2" galvanized steel with concrete imbeds as shown below.

Frame and grate shall be installed so that the cover top, concrete, frame and grate are flush, flat and level with each other as shown below.

Grate frame shall have a minimum 33" opening.

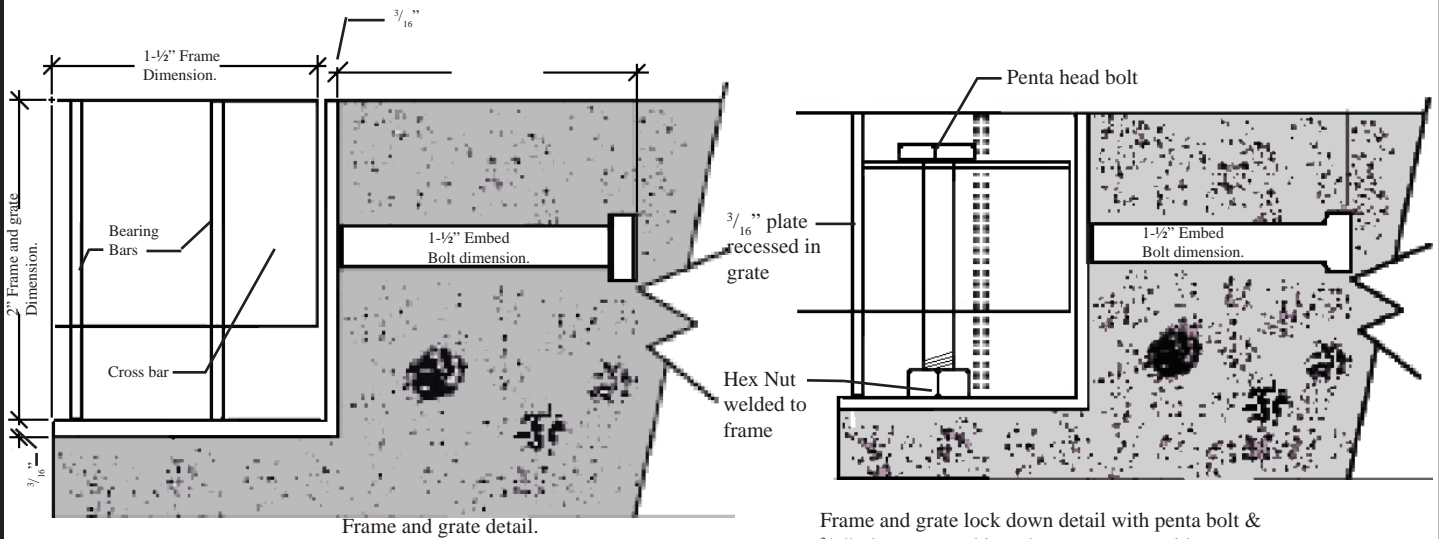

PUBLIC UTILITY DISTRICT #2 OF GRANT COUNTY	Date	12/04/01	COVER 4'8" x 4'8"	ASSEMBLY UNIT		Yes		
	Rev #	10						
	Designer	GW		TDSI	X	TTNI	TMNI	TSNI
	Standards Engineer			22052078				
		AL SILVA						

HAND HOLE, ENCLOSURE, FIBER, COMPOSITE

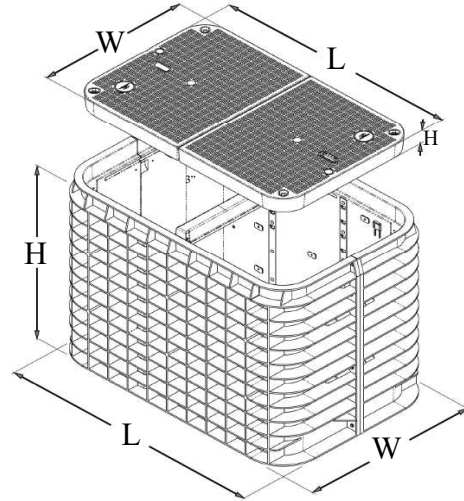

GENERAL: Composite hand hole and cover for fiber applications.

SPECIFICATIONS: Enclosure shall be molded of high density polyethelene (HDPE) meeting ANSI/SCTE 77 TIER 22. The body of the enclosure shall have straight walls with ribbed sidewalls. The interior of the enclosure shall have embedded racking. Cover shall be a "SHIELD X" made of composite material with an anti-slip grid design, capable of withstanding 33,750 lb force. The cover shall have a logo disc with the embossed words "GRANT PUD FIBER", a marker locator device, and a lifting slot equipped with stainless steel pin.
Enclosure must include 1/2" Penta-head bolts with 7/8" heads.

RATING: Driveway, parking lot, and off-roadway applications subject to occasional non-deliberate heavy vehicular traffic.

PURCHASING: UOM: Each Order in quantities of 12 per pallet.

STOCK NUMBER	TYPE	OUTER DIMENSION (inches)						APPROVED MANUFACTURERS & CATALOG NUMBERS
		ENCLOSURE			COVER			CHANNELL
		L	W	H	L	W	H	
22097714	SM FIBER	27½	18⅞	18	23¼	13¾	2	BULKU1324180062310
22097721	OPTIC TAPS	33⅜	21¾	24	30½	17½	2	BULKU1730240062310

Rev. 03-25-22 DH "Reverted large fiber hand hole back to concrete and moved to separate page."
 Rev. 11-05-19 DH "Added larger size box for optic taps."
 Rev. 05-10-19 RP "Removed Pencil/Hubbell as approved manufacturer and replaced with Channell".
 Rev. 05-30-18 DH "Corrected catalog number by removing the "F".

PUBLIC UTILITY DISTRICT #2 OF GRANT COUNTY	Created	09/14/00	HAND HOLE, ENCLOSURE, FIBER, COMPOSITE	ASSEMBLY UNIT	Yes		
	Rev #	9					
	Designer	MB		TDSI X	TTNI	TMNI	TSNI
	Standards Engineer	E. WENKE		22097714			

VAULT & COVER, SPLICING, 9' x 5'

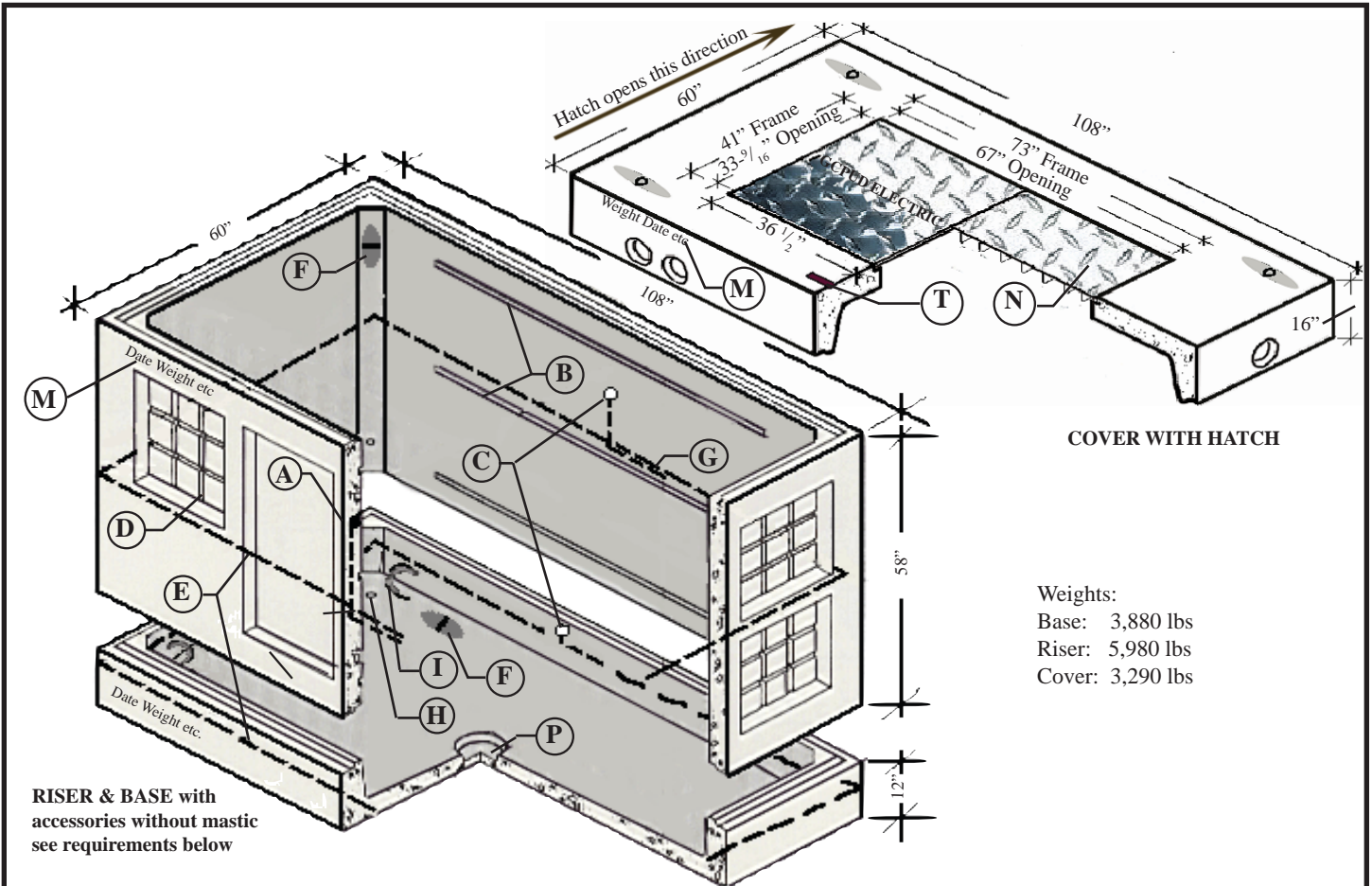

GENERAL: Vault and cover for splicing electric cable.

SPECIFICATIONS: Concrete vault and cover constructed per the Districts Precast Concrete Product Specification #03800: S:\Data\STANDARD\SPECIFICATIONS\District Specs\03800 Precast Concrete Products.
 Each cover shall have the words, “GRANT COUNTY PUD ELECTRIC” or “GCPUD ELECTRIC” either welded, imprinted or embossed in the center or along the concrete as shown above.

PURCHASING: Quantity “Each”
 Include stock page with each purchase request or contract bid document.

STOCK NUMBER	AU#	SIZE			APPROVED MANUFACTURERS & CATALOG NUMBERS		
		L	W	D	UTILITY VAULT	H-2 PRECAST	
22023083	VAULT	U56V	9' 0"	5' 0"	5"10	4484-LA	VB4484B & VB4484D
	COVER		9' 0"	5' 0"	16"	4484-TL2-332P	VLG4484-23PL

Rev. 10-04-12 MHS “ Added item “T” Tag Impression Note, changed title to ‘Vault & Cover’.”
 Rev. 04-12-11 MHS “Changed hatch to USF, added AU# reformed correct specifications.”
 Rev. 05-06-09 DH “Updated H2 catalog number; Added stock page and specifications inclusion note.”
 Rev. 06-25-07 DH “Combined with cover 22142385; Changed rebar size in construction notes; Added shipping note.”

PUBLIC UTILITY DISTRICT #2 OF GRANT COUNTY	Date	12/04/89	VAULT & COVER, SPLICING, 9' x 5'	ASSEMBLY UNIT		Yes		
	Rev #	11						
	Designer	GW		TDSI	X	TTNI	TMNI	TSNI
	Standards Engineer	AL SILVA		22023083				

VAULT & COVER, SPLICING, 9' x 5'

OFF-LOADING: Units shall be shipped on pallets or dunnage. Any units with pallets that are oversized, undersized, damaged, broken, have loose boards, or protruding nails or screws shall not be accepted.

CONSTRUCTION NOTES: Joints shall be constructed so that the various units interlock when assembled. The mastic between sections shall be $\frac{3}{4}$ " thick.

The vault shall be constructed with the following items included:

- A. Exterior Grounding Connection System**
 $\frac{3}{8}$ " dia. steel lead with $\frac{1}{2}$ " dia. bronze grounding inserts & cap protector, 1 each located on each long side of riser, see welding detail below. Total 2.
- B. Galvanized C Channel 4' long**
 Three (3) on each long side of the riser section. Total 6.
- C. Interior Grounding Connection System**
 $\frac{3}{8}$ " dia. steel lead with $\frac{1}{2}$ " dia. bronze grounding inserts & cap protector, 4 each located in the center of the interior riser walls and 2 each located on the interior long sides of the base, see welding detail below. Total 6.
- D. Precast Knockouts**
 On all four (4) sides of riser for installing conduits, see page 1 of two for general locations. As shown.
- E. Grounding Bar**
 Minimum length of 30 feet of #4 rebar around the vault perimeter, one each in the vault body and base. Total 2.
- F. Burke's Lifting Eye**
 4 each in the cover, base and riser. Total 12.
 Size as required for lifting loads imposed.
- G. Weld Detail**
 (see drawing below)
- H. Ground Rod Knockouts 1" dia.**
 Spaced in four corners of the base. Total 4.
- I. Galvanized Pulling Loops**
 Loops shall be capable of supporting the entire weight of the assembled vault.
 2 each positioned 6 to 8 inches from both sides of each corner. Total 8.
- M. Date, Manufacturer, Inspection Stamp & Weight.** Stamped or stenciled on each piece
- N. Hatch**
 Hatch shall be equal to USF double hatch, drawing #57804 with 1/4" aluminum diamond plate, slamlock with penta head bolt, recessed option for padlock and 180° opening with 90° stop. Include interior release handle.
- P. Drain Sump** - centered in the middle of the floor Total 1.
- T. Vault Tag Impression** - 5 1/2" X 2" Impression centered in the middle as shown.
 Total 1.

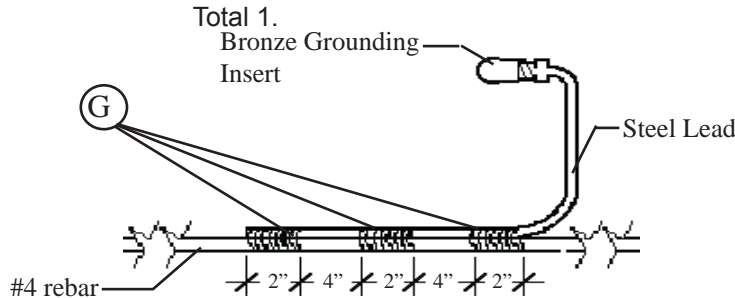

Enlarged View of Weld Detail

PUBLIC UTILITY DISTRICT #2 OF GRANT COUNTY	Date	12/04/89	VAULT & COVER, SPLICING, 9' x 5'	ASSEMBLY UNIT		Yes		
	Rev #	11						
	Designer	GW		TDSI	X	TTNI	TMNI	TSNI
	Standards Engineer	AL SILVA		22023083				

VAULT & COVER, LOADBREAK BUS JUNCTION

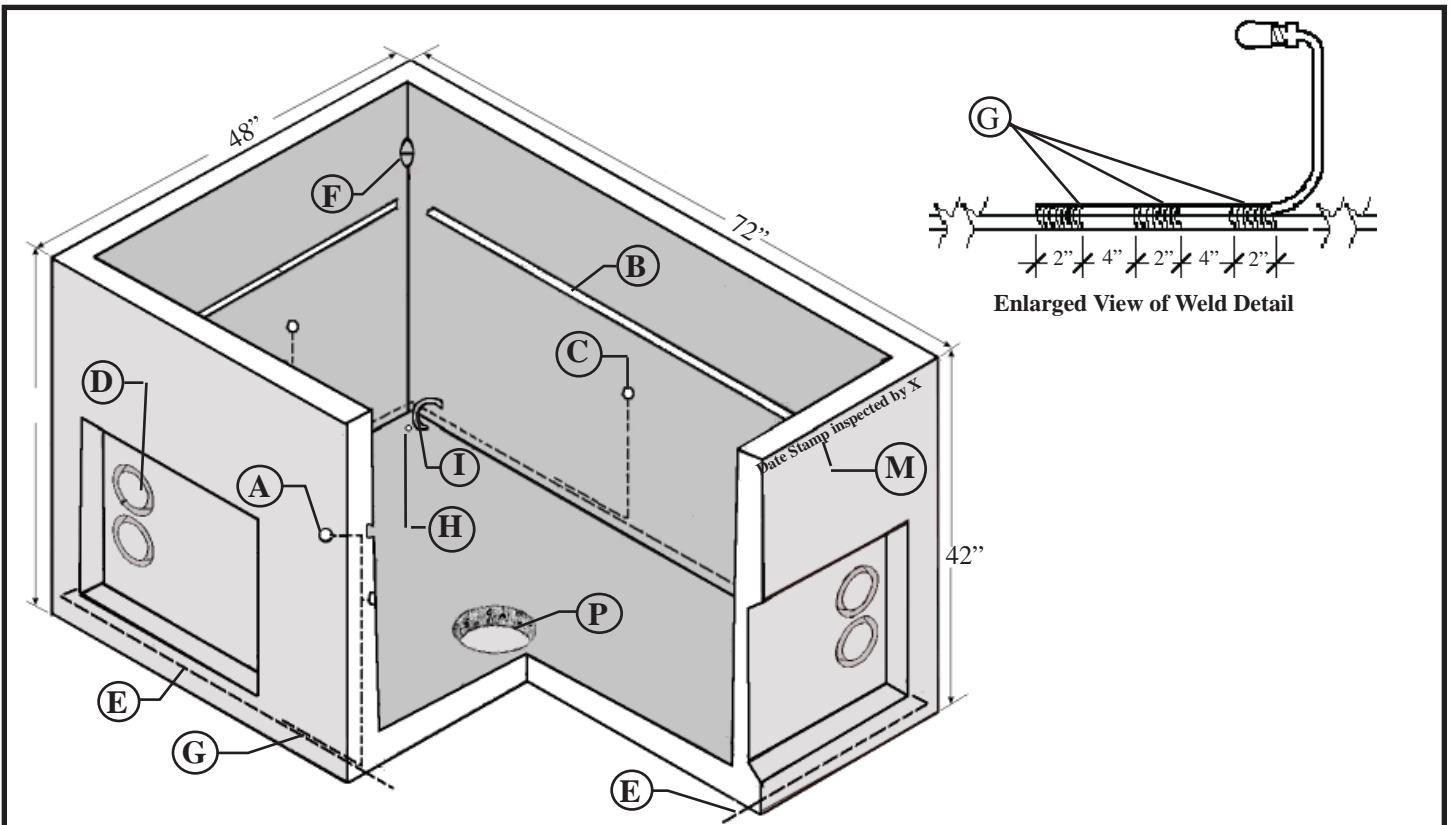

GENERAL: Vault and cover for splicing cable, junctions, and switching.

SPECIFICATIONS: Concrete Vault constructed per the Districts Precast Concrete Product Specification #03800: *S:\Data\STANDARD\SPECIFICATIONS\District Specs\03800 Precast Concrete Products*. Each cover shall have the words, "**GRANT COUNTY PUD ELECTRIC**" or "**GCPUD ELECTRIC**" either welded, imprinted or embossed in the center or along the concrete as shown above.

PURCHASING: UOM: Each
Include stock page with each purchase request or contract bid document.

STOCK NUMBER		AU	SIZE		APPROVED MANUFACTURERS & CATALOG NUMBERS	
			L	W	UTILITY VAULT COMPANY	H-2 PRECAST
22022462	VAULT	U55V	6'	4'	644-L w/ grounding system	VBG464
	COVER		6'8"	4'8"	64-2-332P	----
			6'10"	4'6"	----	VLG460-23PL

Rev. 06-10-15 DH "Changed cover size for H2 Precast.
 Rev. 10-04-12 MHS " Added item "T" Tag Impression Note, changed title to 'Vault & Cover'."
 Rev. 04-12-11 MHS "combined with cover 22152459; Updated specifications, added USF hatch."
 Rev. 05-06-09 DH "Updated H2 catalog number; Added stock page and specifications inclusion note."

PUBLIC UTILITY DISTRICT #2 OF GRANT COUNTY	Date	05/07/91	VAULT & COVER, LOADBREAK BUS JUNCTION				ASSEMBLY UNIT		Yes			
	Rev #	11					TDSI		X	TTNI	TMNI	TSNI
	Designer	HC										
	Standards Engineer	AL SILVA										
			22022462									

VAULT & COVER, LOADBREAK BUS JUNCTION

OFF-LOADING: Vaults with covers shall be shipped on pallets. Any units with pallets that are oversized, undersized, damaged, broken, have loose boards, or protruding nails or screws shall not be accepted.

CONSTRUCTION NOTES: Joints shall be constructed so that the various units interlock when assembled. The vault shall be constructed with the following items included:

- A. Exterior Grounding Connection System**
 $\frac{3}{8}$ " dia. steel lead with $\frac{1}{2}$ " dia. bronze grounding inserts & cap protector, located on each long side of riser. 2 each vault.
- B. Galvanized C Channel 4' long**
 One (1) on each side. 4 each vault.
- C. Interior Grounding Connection System**
 $\frac{3}{8}$ " dia. steel lead with $\frac{1}{2}$ " dia. bronze grounding inserts & cap protector, located on all 4 sides. 4 each vault.
- D. Precast Knockouts**
 On all four (4) sides of riser for installing conduits. As shown.
- E. Grounding Bar #4**
 Minimum length of 20 feet of #4 rebar around the vault perimeter
- F. Burke's Lifting Eye**
 (4) each in vault corners and in each corner on the cover. 8 total to be sized as required for lifting load.
- G. Weld Detail** (see drawing on page 1 of 2.)
- H. Ground Rod Knockouts 1" dia.**
 Spaced evenly on 4 places in the floor of the base. 4 each vault.
- I. Galvanized Pulling Loops**
 Loops shall be capable of supporting the entire weight of the unit. Positioned less than 6" from the corner in each corner. 4 each vault.
- M. Date, Weight & Inspection Stamp** Paper or plastic tags shall not be accepted.
- N. Hatch**
 Hatch shall be equal to USF double hatch, drawing #57804 with $\frac{1}{4}$ " aluminum diamond plate, slamlock with penta head bolt, recessed option for padlock and 180° opening with 90° stop. Include interior release handle.
- P. Drain Sump** - centered in the middle of the floor
- T. Vault Tag Impression** - 5 $\frac{1}{2}$ " X 2" Impression centered in the middle as shown. Total 1.

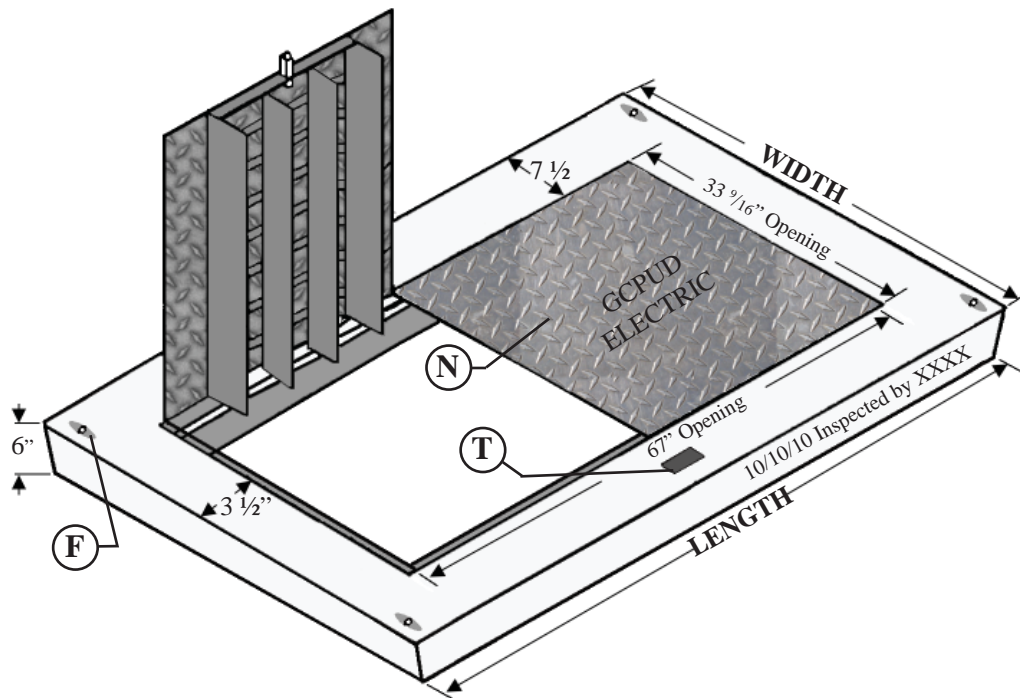

PUBLIC UTILITY DISTRICT #2 OF GRANT COUNTY	Date	05/07/91	VAULT & COVER, LOADBREAK BUS JUNCTION				ASSEMBLY UNIT	Yes
	Rev #	11						
	Designer	HC	TDSI	X	TTNI	TMNI	TSNI	
	Standards Engineer	AL SILVA	22022462					

VAULT, JUNCTION, 4'8" x 4'8"

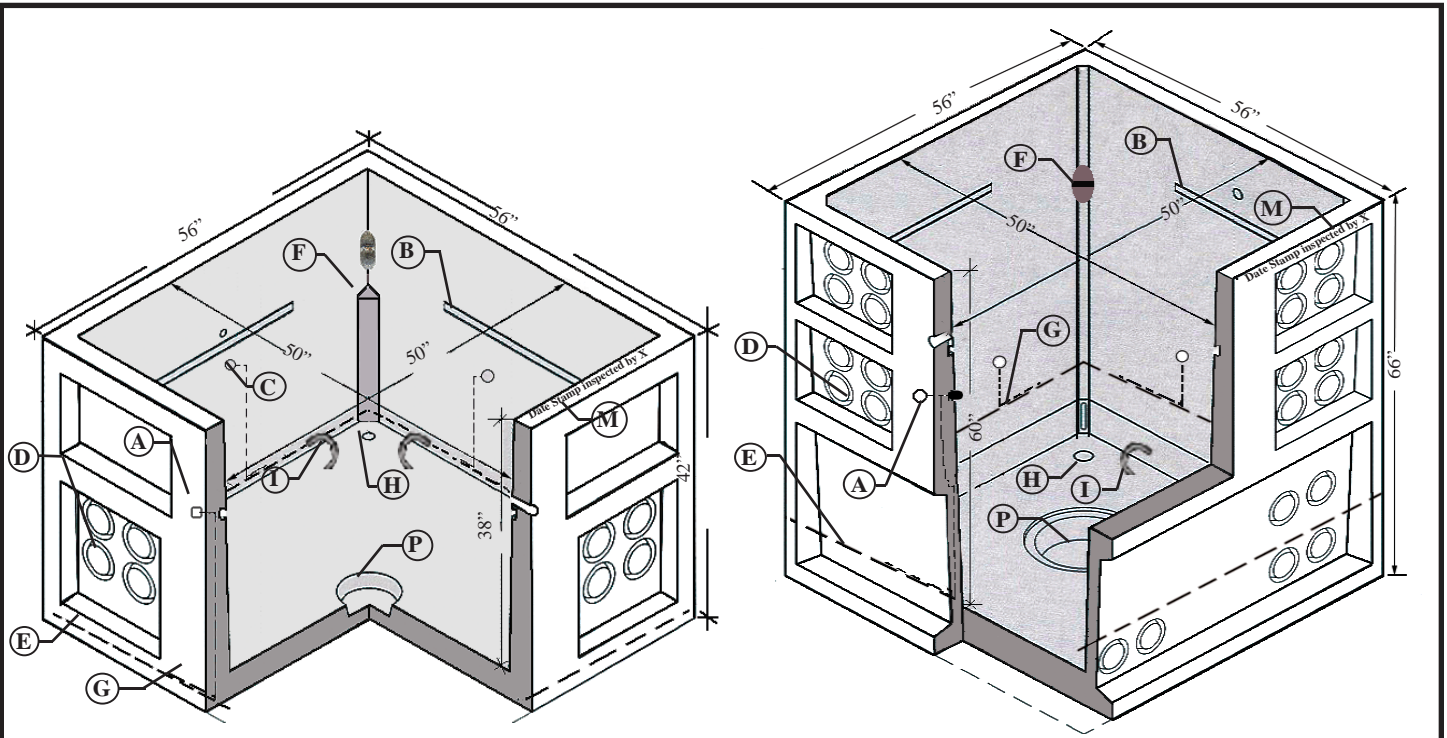

GENERAL:

Vault for electrical cable switching and transformer installations

SPECIFICATIONS:

Concrete Vault constructed per the Districts Precast Concrete Product Specification #03800: *S:\Data\STANDARD\SPECIFICATIONS\District Specs\03800 Precast Concrete Products* Unit must support 4000 lbs. transformer loading.

PURCHASING:

Include stock page and District specification with each purchase request.

For various applications see these stock numbers.

#22022491 for Farm Irrigation Cover. (Assembly Unit #U48VF)

#22052078 for Secondary Cabinet Cover. (Assembly Unit # U50VS)

#22152378 for Junction Cover. (Assembly Unit # U54V)

#22152379 for Fiber Cover. (Assembly Unit #J232)

#22402486 for 45 kVA - 500 kVA 3 phase Transformer Cover. (Assembly Unit # U47V)

#22412478 for 15 kVA - 167 kVA 1 phase Transformer Cover. (Assembly Unit # U46V)

OFF-LOADING:

Vaults shall be shipped on pallets. Pallets that are oversized, undersized, damaged, broken, have loose boards, or protruding nails or screws shall not be accepted.

STOCK NUMBER	ASSEMBLY UNIT	HEIGHT	APPROVED MANUFACTURERS & CATALOG NUMBERS	
			UTILITY VAULT	H-2 PRECAST
22022374	J232, U47V U46V, U48VF, U50VS, U54V	3'6"	504-L w/ grounding system	VBG554
22022377	U54D	5'6"	506-L w/ grounding system	VBG556

Rev. 09-30-13 DH "Added AU for farm vault."

Rev. 07-06-11 DH "Corrected Assembly Unit information; added AU for fiber."

Rev. 04-12-11 MHS "Updated specifications added AU #s."

Rev. 05-06-09 DH "Updated H2 catalog number; Added stock page and specifications inclusion note."

PUBLIC UTILITY DISTRICT #2 OF GRANT COUNTY	Date	05/06/91	VAULT, JUNCTION, 4'8" x 4'8"				ASSEMBLY UNIT	Yes		
	Rev #	11								
	Designer	HC					FDSI <input checked="" type="checkbox"/>	TTNI	TMNI	TSNI
	Standards Engineer	AL SILVA					22022374			

VAULT, JUNCTION, 4'8" x 4'8"

CONSTRUCTION NOTES:

The vault shall be constructed with the following items included:

- A. Exterior Grounding Connector System**
 $\frac{3}{8}$ " dia. steel lead with $\frac{1}{2}$ " dia. bronze grounding inserts & cap protector, 1 each located on each long side of riser, see welding detail below. Total 2.
- B. Galvanized C Channel 4' long**
 One (1) on each side of the riser section. Total 4.
- C. Interior Grounding Connector System**
 $\frac{3}{8}$ " dia. steel lead with $\frac{1}{2}$ " dia. bronze grounding inserts & cap protector, 4 each located in the center of the interior riser walls, see welding detail below. Total 4.
- D. Precast Knockouts**
 On all four (4) sides of riser for installing conduits, see page 1 of two for general locations. As shown.
- E. Grounding Bar**
 Minimum length of 20 feet of #4 rebar around the vault perimeter, one each in the vault wall. Total 1.
- F. Burke's Lifting Eye**
 4 each in the riser walls. Total 4.
 Size as required for lifting loads imposed.
- G. Weld Detail**
 (see drawing below)
- H. Ground Rod Knockouts 1" dia.**
 In two opposite corners 2 places in the floor of the riser. Total 2.
- I. Galvanized Pulling Loops**
 Loops shall be capable of supporting the entire weight of the assembled vault.
 4 each positioned in the center of the wall on each side of the riser floor. Total 4.
- M. Date, Manufacturer, Inspection Stamp & Weight.** Stamped or stenciled on each piece
- P. Drain Sump** - centered in the middle of the floor Total 1

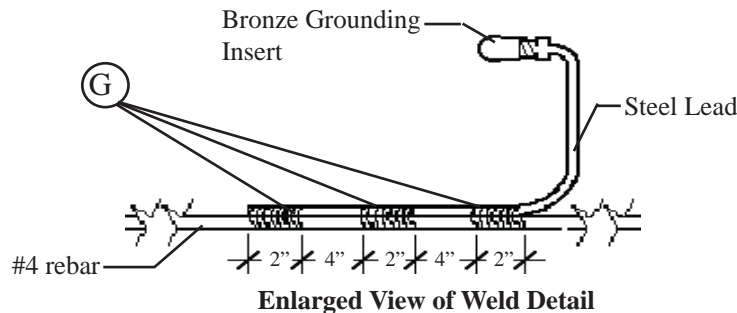

PUBLIC UTILITY DISTRICT #2 OF GRANT COUNTY	Date	05/06/91	VAULT, JUNCTION, 4'8" x 4'8"	ASSEMBLY UNIT		Yes		
	Rev #	11						
	Designer	HC		TDSI	X	TTNI	TMNI	TSNI
	Standards Engineer	AL SILVA		22022374				

VAULT & COVER, HANDHOLE, FIBER

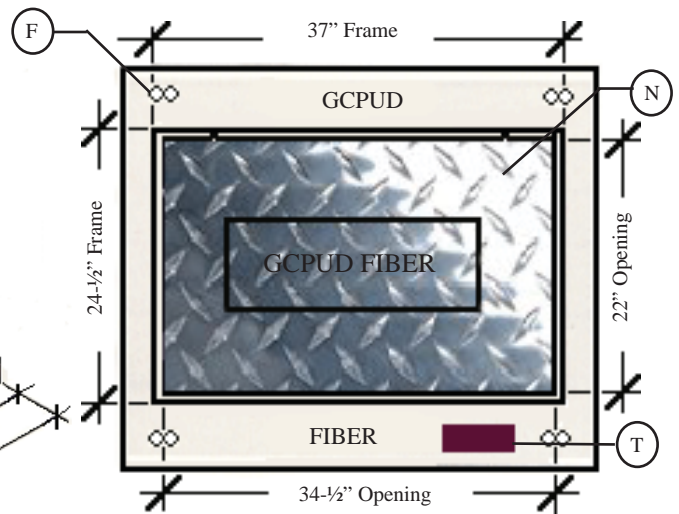
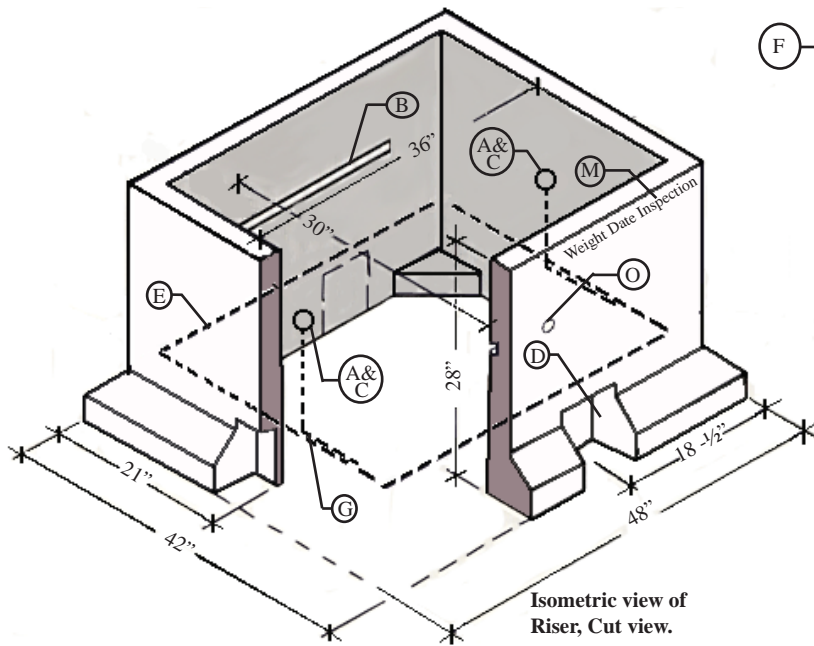

Cover with Hatch, Name shall be either in concrete or lid as shown

Weights: Approximate:
Handhole 1,250 lbs.
Cover: 525 lbs.

GENERAL: Vault for fiber cable junctions, storage & splice enclosures.

SPECIFICATIONS: Concrete Vault constructed per the Districts Precast Concrete Product Specification #03800: *S:\Data\STANDARD\SPECIFICATIONS\District Specs\03800 Precast Concrete Products*. Each cover shall have the words, “**GRANT COUNTY PUD FIBER**” or “**GCPUD FIBER**” either welded, imprinted or embossed in the center or along the concrete as shown above.

Vault walls must support 4,000 psi side wall pressure for traffic along side.

PURCHASING: Quantity “Each”
Include stock page with each purchase request or contract bid document. See page 2 of 2 for dimensions.

OFF-LOADING: Handholes shall be shipped on pallets. Any units with pallets that are oversized, undersized, damaged, broken, have loose boards, or protruding nails or screws shall not be accepted.

STOCK NUMBER	AU#	SIZE			APPROVED MANUFACTURERS & CATALOG NUMBERS		
		L	W	D	UTILITY VAULT	H-2 PRECAST	
22022329	VAULT	J230	48”	42”	28”	3642 - BL	VBG-3642
	COVER		42”	36”	4”	3642-2436GCPUD-FIBER	VLG3642-2436PL-FIBER

Rev. 10-04-12 MHS “ Added item “T” Tag Impression Note, changed title to ‘Vault & Cover’.”
 Rev. 04-25-11 MHS “Changed hatch to USF or equal, and added AU#, added ground system.”
 Rev. 08-18-09 MHS “Reformatted page and changed cover stamp/imprint to ‘fiber’.”
 Rev. 07-11-05 DJ “Added off-Loading notes, date and inspection requirements.”

PUBLIC UTILITY DISTRICT #2 OF GRANT COUNTY	Date	02/02/88	VAULT & COVER, HANDHOLE, FIBER	ASSEMBLY UNIT		Yes	
	Rev #	6					
	Designer	MB		TDSI <input checked="" type="checkbox"/>	TTNI	TMNI	TSNI
	Standards Engineer	AL SILVA		22022329			

VAULT & COVER, HANDHOLE, FIBER

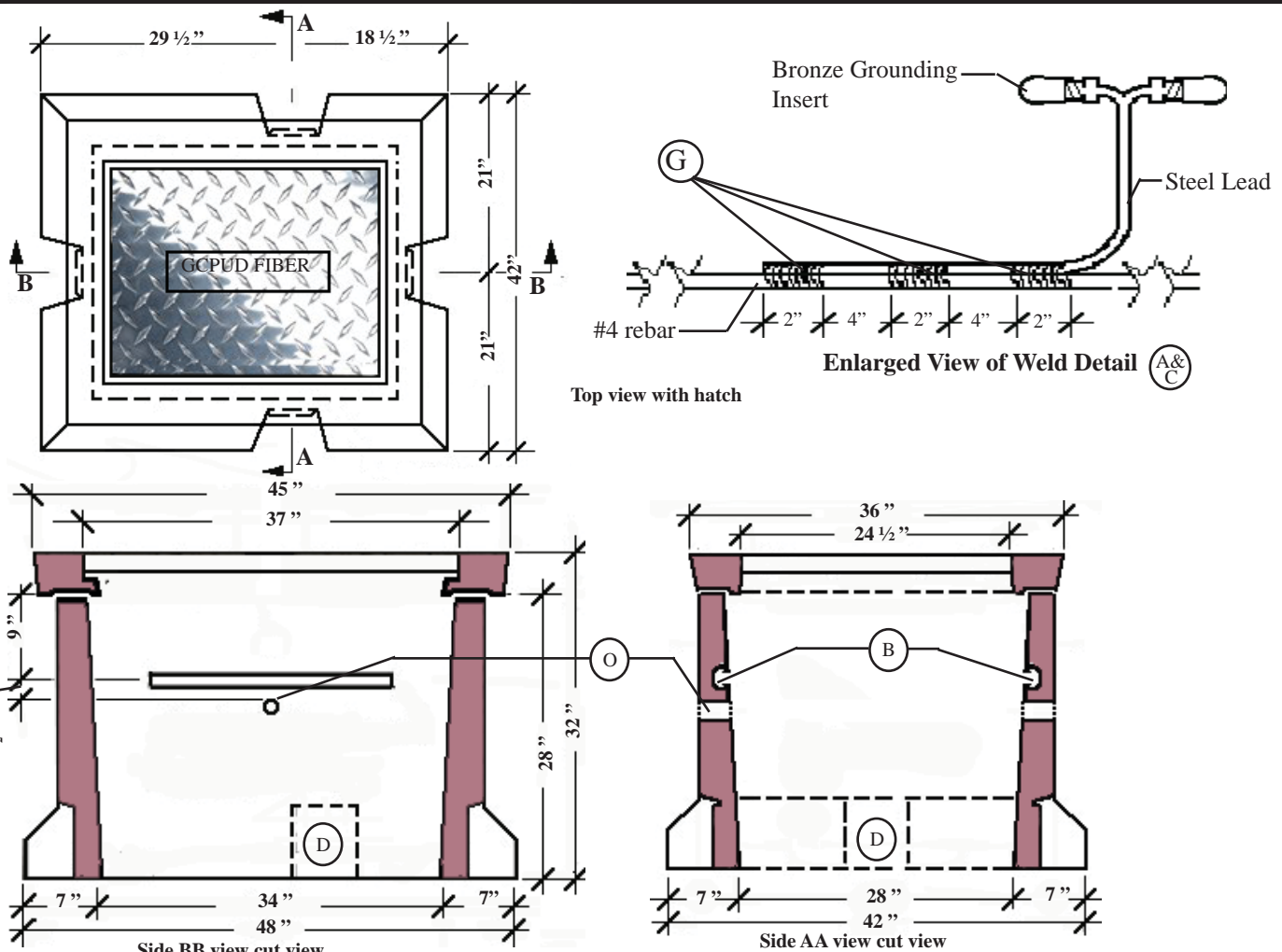

Construction Notes

A&C. Exterior & Interior Ground Connection System.

3/8" dia. steel lead with 1/2" dia. bronze grounding inserts & cap protector, 2 each located back to back in the non-channel walls, see welding detail above. Total 2.

B. Galvanized C Channel 4' long

Two (2) 26" (inches) long on opposite sides of the riser section. Total 2.

D. Precast Knockouts

On all four (4) sides of riser for installing conduits, see page 2 of two for general locations. As shown.

E. Grounding Bar

Minimum length of 20 feet of #4 rebar around the vault perimeter, 4" above the knockouts. Bar shall be lapped to fit. Total 1.

F. Burke's Lifting Eye (Inserts shall not be accepted.)

4 each in the cover. Total 4. Size as required for lifting loads imposed.

G. Weld Detail for Ground Connections. See detail above.

M. Date, Manufacturer, Inspection Stamp & Weight. Stamped or stenciled on each piece. Paper or plastic shall not be accepted

N. Hatch

Hatch shall be equal to USF double hatch, drawing #57013 with 1/4" aluminum diamond plate, slamlock with penta head bolt, recessed option for padlock and 180° opening with 90° stop.

O. Lifting Holes

Handhole wall section shall have two (2) 1 - 1/2" lifting holes formed on two sides as shown on the drawing. Holes shall be round and smooth location shown. Total 2

T. Vault Tag Impression - 5 1/2" X 2" Impression off set on the opening side as shown. Total 1.

PUBLIC UTILITY DISTRICT #2 OF GRANT COUNTY	Date	02/02/88	VAULT & COVER, HANDHOLE, FIBER	ASSEMBLY UNIT		Yes		
	Rev #	6						
	Designer	MB		TDSI	X	TTNI	TMNI	TSNI
	Standards Engineer	AL SILVA		22022329				

VAULT & COVER, DEAD FRONT SWITCHGEAR

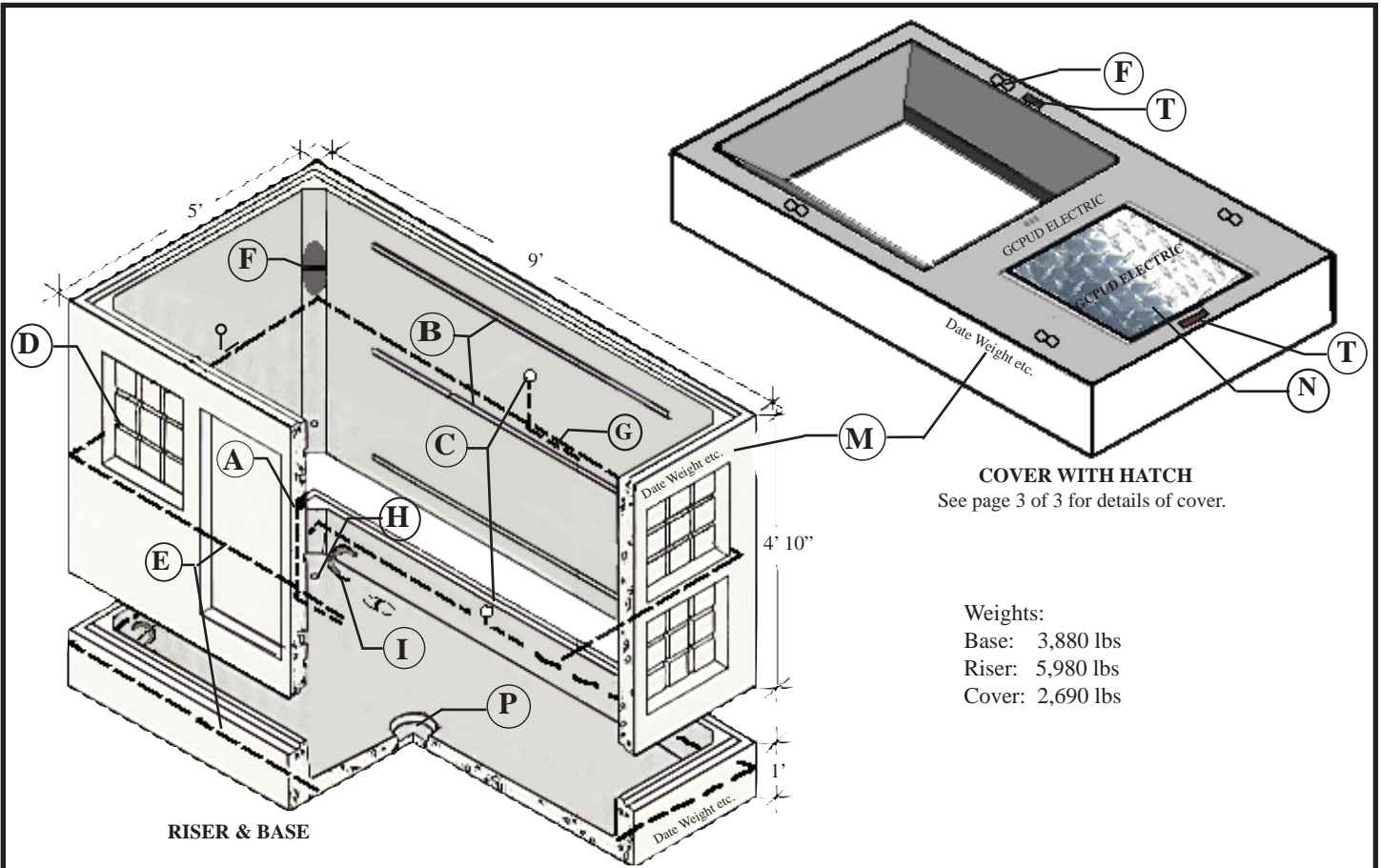

COVER WITH HATCH
See page 3 of 3 for details of cover.

Weights:
 Base: 3,880 lbs
 Riser: 5,980 lbs
 Cover: 2,690 lbs

GENERAL: Vault and cover for PSE/PME dead front switch gear.

SPECIFICATIONS: Concrete vault and cover constructed per the Districts Precast Concrete Product Specification #03800: S:\Data\STANDARD\SPECIFICATIONS\District Specs\03800 Precast Concrete Products.
 Each cover shall have the words, “**GRANT COUNTY PUD ELECTRIC**” or “**GCPUD ELECTRIC**” either welded, imprinted or embossed in the center or along the concrete as shown above.

PURCHASING: Quantity “Each”
 Include stock page with each purchase request or contract bid document.

STOCK NUMBER	AU #	SIZE			APPROVED MANUFACTURERS & CATALOG NUMBERS		
		L	W	D	UTILITY VAULT	H-2 PRECAST	
22022092	VAULT	U56SG	9'	5'	5'10"	4484-LA	VB4484B and VB4484D
	COVER		9'	6' 8"	varies	4484-2436-6552 PAD	TPG4484-2436PL-6265

Rev. 10-04-12 MHS “ Added item “T” Tag Impression Note, changed title to ‘Vault & Cover’.”
 Rev. 04-12-11 MHS “Changed hatch to USF or equal. added AU#.”
 Rev. 03-02-10 MHS “Updated drawings and specifications.”
 Rev. 04-10-09 DH “Updated H 2 catalog number; Added stock page and specifications inclusion note.”

PUBLIC UTILITY DISTRICT #2 OF GRANT COUNTY	Date	12/04/89	VAULT & COVER, DEAD FRONT SWITCHGEAR	ASSEMBLY UNIT		Yes		
	Rev #	11						
	Designer	LW		TDSI	X	TTNI	TMNI	TSNI
	Standards Engineer	AL SILVA		22022092				

VAULT & COVER, DEAD FRONT SWITCHGEAR

OFF-LOADING: Units shall be shipped on pallets or dunnage. Any units with pallets that are oversized, undersized, damaged, broken, have loose boards, or protruding nails or screws shall not be accepted.

CONSTRUCTION NOTES: Joints shall be constructed so that the various units interlock when assembled. The mastic between sections shall be $\frac{3}{4}$ " thick.

The vault shall be constructed with the following items included:

A. Exterior Grounding Connection System

$\frac{3}{8}$ " dia. steel lead with $\frac{1}{2}$ " dia. bronze grounding inserts & cap protector, 1 each located on each long side of riser, see welding detail below. Total 2.

B. Galvanized C Channel 4' long

Three (3) on each long side of the riser section. Total 6.

C. Interior Grounding Connection System

$\frac{3}{8}$ " dia. steel lead with $\frac{1}{2}$ " dia. bronze grounding inserts & cap protector, 4 each located in the center of the interior riser walls and 2 each located on the interior long sides of the base, see welding detail below. Total 6.

D. Precast Knockouts

On all four (4) sides of riser for installing conduits, see page 1 of 2 for general locations. As shown.

E. Grounding Bar

Minimum length of 30 feet of #4 rebar around the vault perimeter, one each in the vault body and base. Total 2.

F. Burke's Lifting Eye

4 each in the cover, base and riser. Total 12.
Size as required for lifting loads imposed.

G. Weld Detail (see drawing below)

H. Ground Rod Knockouts 1" dia.

Spaced evenly in each corner 4 places in the floor of the base. Total 4.

I. Galvanized Pulling Loops

Loops shall be capable of supporting the entire weight of the assembled vault. 2 positioned 6 to 8 inches from each corner on each side of the base. Total 8.

M. Date, Manufacturer, Inspection Stamp & Weight.

Stamped or stenciled on each piece. Paper or plastic tags shall not be accepted.

N. Hatch

Hatch shall be equal to USF, drawing #57013 with $\frac{1}{4}$ " aluminum diamond plate, slamlock with penta head bolt, recessed option for padlock and 180° opening with 90° lock position. Include interior release handle.
Minimum hatch opening shall be 34- $\frac{1}{2}$ " X 22" (inches)

P. Drain Sump - centered in the middle of the floor Total 1.

T. Vault Tag Impression - 5 - $\frac{1}{2}$ " x 2" One centered in the middle of right side opening & one centered along the hatch as shown. Total 2.

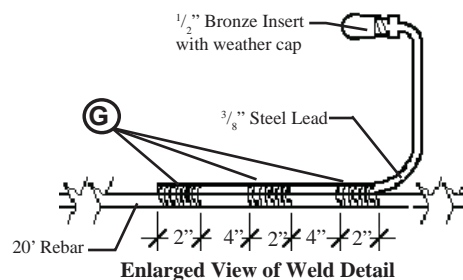

PUBLIC UTILITY DISTRICT #2 OF GRANT COUNTY	Date	12/04/89	VAULT & COVER, DEAD FRONT SWITCHGEAR	ASSEMBLY UNIT		Yes		
	Rev #	11						
	Designer	LW		TDSI	X	TTNI	TMNI	TSNI
	Standards Engineer	AL SILVA		22022092				

Vault & COVER, DEAD FRONT SWITCHGEAR

Cross Section Views of the Vault Top.

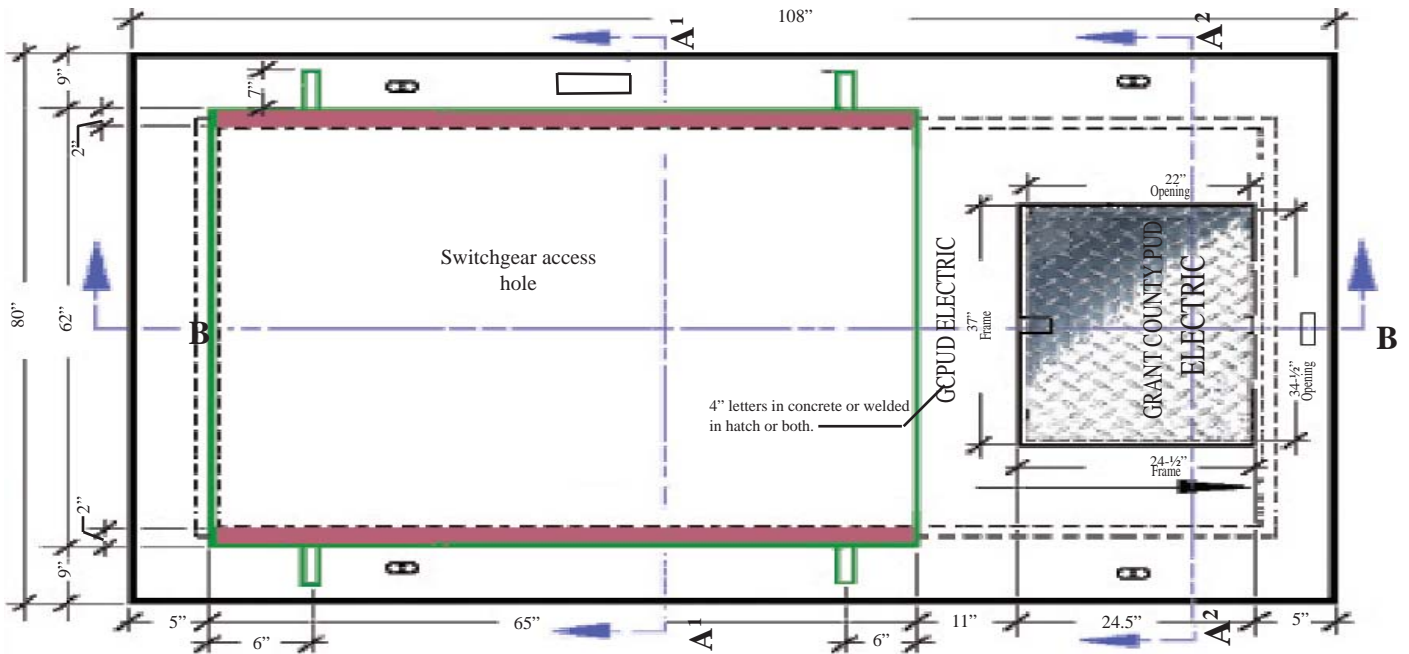
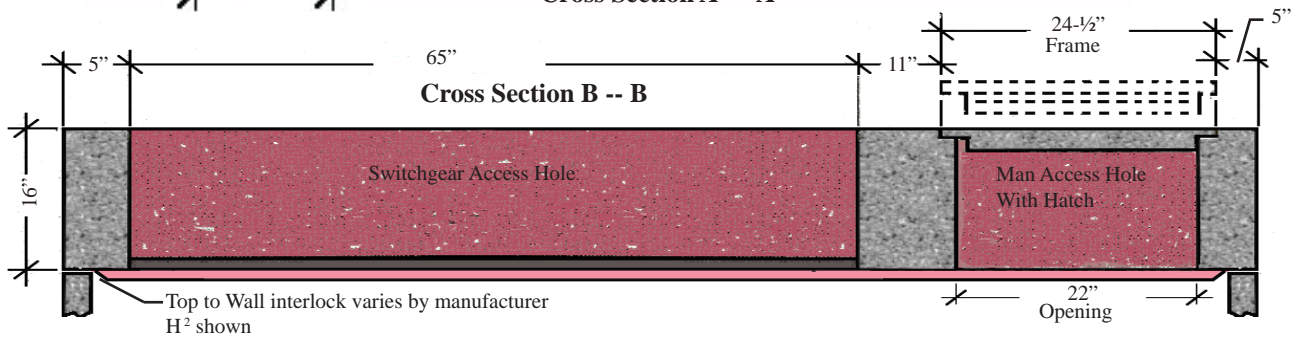
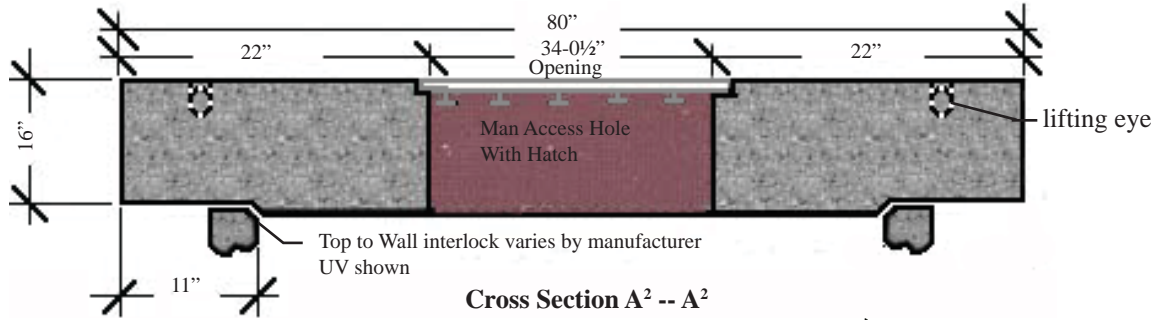
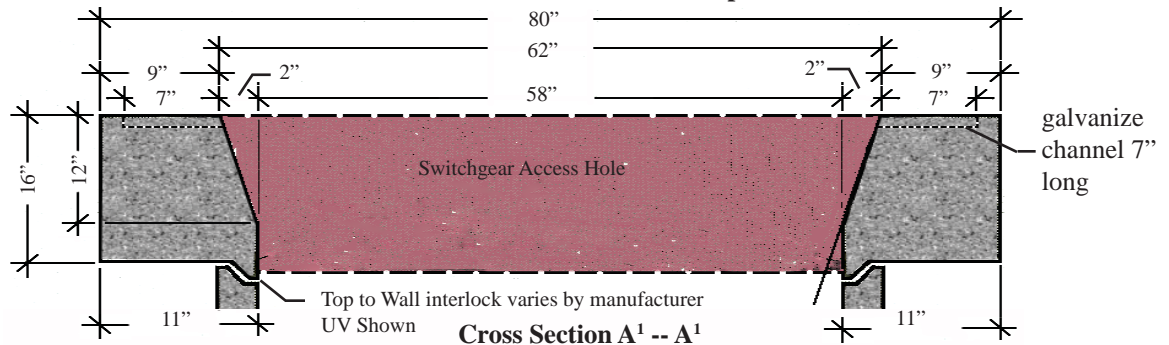

PUBLIC UTILITY DISTRICT #2 OF GRANT COUNTY	Date	12/04/89	VAULT & COVER, DEAD FRONT SWITCHGEAR				ASSEMBLY UNIT		Yes	
	Rev #	11					TDSI		X	TTNI
	Designer	LW								
	Standards Engineer	AL SILVA			22022092					

UG PRIMARY CABLE, 15kV EPR-INSULATED, ALUMINUM

ALUMINUM CONDUCTOR, COPPER CONCENTRIC NEUTRAL, JACKETED

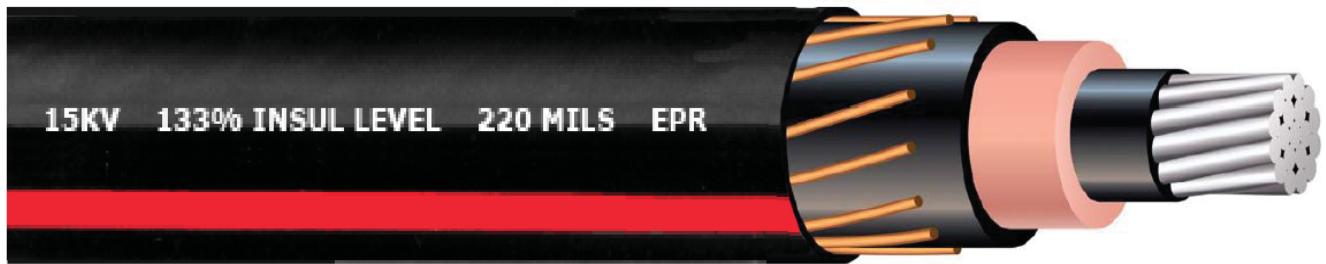

GENERAL: 15kV Jacketed primary aluminum distribution cable for underground installations.

SPECIFICATIONS: Cable shall be manufactured per District Specifications 16120.4 ..\Data\STANDARD\ SPECIFICATIONS\District Specs - Current written. The cable shall consist of layers of

- Stranded Aluminum Conductor
- Semiconducting EPR conductor shield
- Insulation EPR, 133% level
- Semiconducting EPR insulation shield
- Concentric neutral conductor-bare copper wires; full, 1/3, or 1/6 as required
- Outer jacket 220 mil black EPR with 3 extruded red ID stripes and NESC lightning bolt

PURCHASING: UOM: foot
Include stock page and District specification with each purchase request and contract.

STOCK NUMBER	COND. SIZE	STR	COPPER NEUTRAL (NO. X AWG)	NOM. O.D (inches)	NET WT (lbs/1000')	APPROVED MANUFACTURERS & CATALOG NUMBERS			
						OKONITE	KERITE	PRYSMIAN	GENERAL CABLE
COMPRESSED - FULL NEUTRAL									
09300610	2	7	10 x 14	1.08	595	161-23-3060	Per Specification	QNM010A	352817
09300612	1/0	19	16 x 14	1.15	752	161-23-3072		QNQ010A	127295
COMPRESSED - 1/3 NEUTRAL									
09300616	4/0	19	11 x 14	1.30	889	160-23-3081	Per Specification	QNT000A	859119
09300636	350	37	18 x 14	1.50	1280	160-23-3090		QNV000A	196029
09300676	750	61	15 x 10	1.96	2237	160-23-3096		QNX000A	864446
09300691	1000	61	20 x 10	2.15	2875	160-23-3099		QNY000A	629316
COMPACT - 1/6 NEUTRAL									
09300695	1100	61	18 x 12	2.01	2471	160-23-9590	As Required		
COMPRESSED, FILLED STRAND - 1/3 NEUTRAL									
09300876	750	61	15 x 10	1.95	2244	162-23-3096	Per Specification	QNX020A	269579

Rev. 09-07-16 DH "Removed 16120.4A reference and pre-qual information; updated specifications; Removed Kerite cat numbers."
 Rev. 02-17-16 SW "Added 09300695, updated specification numbers"
 Rev. 07-16-10 DH "Updated specification number; Added additional packaging information."
 Rev. 06-21-10 DH "Added O.D and weight; Corrected text in photo."

PUBLIC UTILITY DISTRICT #2 OF GRANT COUNTY	Date	03/17/95	UG PRIMARY CABLE, 15kV EPR-INSULATED, ALUMINUM	ASSEMBLY UNIT		Yes	
	Rev #	8					
	Designer	LL		TDSI <input checked="" type="checkbox"/>	TTNI	TMNI	TSNI
	Standards Engineer	E. WENKE		09300610			

UG PRIMARY CABLE, 15kV EPR-INSULATED, ALUMINUM

- 1.0 Scope** This specification covers 15kV underground primary distribution cable-jacketed
- 2.0 Standard Reference:**
The materials, construction and tests for conductors shall conform to the applicable requirements of the latest publication of the American Society for Testing and Materials (ASTM), American National Standards Institute (ANSI), National Electrical Manufacturers Associations (NEMA), Association of Edison Illuminating Companies (AEIC), and Insulated Cable Engineering Association (ICEA).
- 3.0 Specifications:**
- 3.1 Jacketed underground distribution cable shall be rated for 15kV application with aluminum conductor.
 - 3.2 Cable shall have a temperature rated to 105° C.
 - 3.3 Cable shall be approved for direct burial, conduit installation, and underground duct banks.
 - 3.4 The outer jacket shall be marked with a continuous red identification stripe, manufacturer name, voltage rating, insulation factor, etc. as stated in specification 16120.4.
- 4.0 Packaging:**
- 4.1 The conductor shall be supplied on non-returnable reels in standard packaging lengths for the reel size specified. The packaging lengths shall not exceed 5% over nor 0% under the standard packaging length. Reel sizes shall be a minimum of 2 inch larger than the wound conductor. Recycled reels shall not be accepted.
 - 4.2 The conductor shall be level wound reels. Wooden reels shall be used for all conductors; wooden reels shall have counter sunk bolt ends and nuts. **Reels with protruding nuts and/or bolts shall not be accepted.** The conductor shall have Level 2 protection over outer layer of cable in accordance with NEMA WC26. Wrap shall be secured with 2 steel bandings.
 - 4.3 Each reel shall be tagged with two shipping tags. One tag shall be weather protected and securely attached to the outside of the reel flange. The second tag shall be stapled or secured on the inside of the flange. Each tag shall contain the following information.

<ul style="list-style-type: none"> a. Destination b. Reel Number c. PUD Purchase Order Number d. Manufacturer's Name e. Date of Manufacturer f. Footage of Cable on Reel g. Beginning cable footage number 	<ul style="list-style-type: none"> h. Ending cable footage number i. Number, Type and Size of Conductor j. Cable Configuration k. Thickness and Type of Insulation l. Voltage Rating m. Gross, Tare, and Net Weight n. DO NOT UPEND. * Bright Red or Orange * Min. 2" high * appropriate warning symbol
---	--
 - 4.4 Reel type and dimensions as specified per specification 16120.4 unless otherwise noted.

PUBLIC UTILITY DISTRICT #2 OF GRANT COUNTY	Date	03/17/95	UG PRIMARY CABLE, 15kV EPR-INSULATED, ALUMINUM	ASSEMBLY UNIT		Yes		
	Rev #	8						
	Designer	LL		TDSI	X	TTNI	TMNI	TSNI
	Standards Engineer	E. WENKE		09300610				

CABLE, URD SINGLE CONDUCTOR, 600V, USE-2, ALUMINUM



GENERAL: For secondary distribution, station control wiring in conduits or ducts rated at 600 volts or less.

SPECIFICATIONS: Conductors shall be stranded, compressed 1350-H19 aluminum, insulated with crosslink polyethylene. Conductors shall meet or exceed the following applicable specifications: ASTM B-230, B-231, B-766, ICEA S-66-524, and UL standard 854 for Type USE-2.

PURCHASING: Quantity per foot.

STOCK NUMBER	COND. SIZE	STR	APPROX. CABLE OD (INCHES)	AMPACITY		APPROVED MANUFACTURER & CATALOG NUMBERS		
				DIRECT BURIED	IN DUCTS	OKONITE	CME	SOUTHWIRE
09200608	6	7	.31	19	65			
09200609	4	7	.35	120	85			
09200610	2	7	.41	155	115			

Rev. 10-11-07 DH "Formerly 09722000-09722002; Deleted 09722005-09722009; changed UOM to ft.; added CME and Southwire."
 Rev. 06-15-05 DH "Updated to PageMaker; Added specifications and second page for product info."

PUBLIC UTILITY DISTRICT #2 OF GRANT COUNTY	Date	01/07/79	CABLE URD SINGLE CONDUCTOR, USE-2, 600V, AL	ASSEMBLY UNIT		Yes	
	Rev #	3		SUBSTITUTIONS		Approval Required	
	Designer	AS		TDSI <input checked="" type="checkbox"/>	TTNI	TMNI	TSNI
	Standards Engineer A. SILVA			09200608			

CABLE, URD SINGLE CONDUCTOR, 600V, USE-2, ALUMINUM

1.0 Scope This specification covers 600V underground service entrance cable.

2.0 Standard Reference:

The materials, construction and tests for conductors shall conform to the applicable requirements of the latest publication of the American Society for Testing and Materials (ASTM), American National Standards Institute (ANSI) and National Electrical Manufacturers Associations (NEMA).

3.0 Specifications:

3.1 Conductors shall be UL-listed Type RHH, RHW-2, or USE-2, suitable for operation at 600 volts or less in wet or dry locations.

3.2 Cable shall have a temperature rated to 90° C.

3.3 Cable shall be approved for direct burial, conduct insulation, and underground duct.

4.0 Packaging:

4.1 The conductor shall be supplied on non-returnable reels in standard packaging lengths for the reel size specified. The packaging lengths shall not exceed 5% over nor 5% under the standard packaging length. Reel sizes shall be a minimum of 1-1/2 inch larger than the wound conductor.

4.2 The conductor shall be level wound reels. For conductor sizes up to #2 reels may be plastic. Wooden reels may be used for all conductors; wooden reels shall have counter sunk bolt ends and nuts.* The conductor shall be protected by heavy fiberboard wrapping secured with steel banding.

4.3 Each reel shall be tagged with two shipping tags. One tag shall be weather protected and securely attached to the outside of the reel flange. The second tag shall be stapled or secured on the inside of the flange. Each tag shall contain the following information.

- a. Product Identification
- b. Item Description
- c. Conductor Length
- d. **Gross, Tare and Net Weight**
- e. PUD Purchase Order Number

4.4 Reel type and dimensions shall be specified with each other.

***Note: Reels with protruding nuts and/or bolts shall not be accepted.**

PUBLIC UTILITY DISTRICT #2 OF GRANT COUNTY	Date	01/07/79	CABLE URD SINGLE CONDUCTOR, USE-2, 600V, AL				ASSEMBLY UNIT		Yes
	Rev #	3					SUBSTITUTIONS		Approval Required
	Designer	AS	TDSI	X	TTNI	TMNI	TSNI		
	Standards Engineer	A. SILVA	09200608						

MULTI-CONDUCTOR, UG, 600V, ALUMINUM



Duplex Secondary
1 conductor, 1 neutral



Triplex Secondary
2 conductors, 1 neutral



Quadruplex Secondary
3 conductors, 1 neutral

GENERAL: For secondary distribution and underground service at 600 volts or less.

SPECIFICATIONS: Conductors shall be stranded, compressed 1350-H19 aluminum, insulated with vulcanized interlinked polyethylene. Neutrals shall have three yellow extruded stripes located at 120° intervals. Cables shall have sequential footage marks. Conductor shall meet or exceed the following applicable specifications: ASTM B-230, B-231, B-786, ICEA S-66-524, and UL standard 854 for Type USE-2. See District Specification Section 16240.2.

PACKAGING: Conductor shall be supplied on non-returnable reels in either "cut to order" or standard lengths as specified. The conductor shall be level wound on the reel. Reel sizes shall be a minimum of 1-1/2" inch larger than the wound conductor. Conductor shall be protected by heavy wrapping, either heavy fiberboard or 10 mil. plastic. Package material shall have two shipping/loading tags: A weather protected tag shall be attached to the reel secure enough for shipping and handling. The second tag shall be stapled or glued to the reel face. Each tag shall contain the following in a legible print or type: Product identification, Item description, Conductor length, Gross, and Net weight. The District purchase order number shall be stamped or marked on the reel and both tags.

PURCHASING: Quantity per feet.

STOCK NUMBER	POWER CONDUCTORS			NEUTRAL CONDUCTORS			APPROX. NET WT (lb/M ft.)	CODE NAME
	SIZE	STR	INSUL. (mils)	SIZE	STR	INSUL. (mils)		
DUPLEX								
09102004	4	7	60	4	7	60	135	DELGADO
09102006	6	7	60	6	7	60	95	CLAFLIN
TRIPLEX								
09103010	2	7	60	2	7	60	292	RAMAPO
09103013	2/0	19	80	2/0	19	80	559	HUNTER
09103012	1/0	19	80	2	7	60	407	BRENAU
09103016	4/0	19	80	2/0	19	80	738	SWEETBRIAR
09103036	350	37	95	4/0	19	80	1157	WESLEYAN
QUADRUPLEX								
09104010	2	7	60	4	7	60	377	DYKE
09104013	2/0	19	80	1	19	80	723	SYRACUSE
09104016	4/0	19	80	2/0	19	80	1063	WAKE FORREST
09104036	350	37	95	4/0	19	80	1598	SLIPPERY ROCK

Rev. 11-26-08 MHS "Added Duplex numbers; Changed page number; Removed 'Yellow Neutral' column; ."

Rev. 10-11-07 DH "formerly 09722302 - 09722609; Deleted 09722307; Changed UOM to ft. from lbs.;

Rev. 04-04-07 DH "Changed Title; Separated Triplex and Quad types; Changed cond. no. for 09722302-7; Reformatted page."

Rev. 11-17-04 MS "Deleted 09722405 - 2/0 #2-19 strand, code Bliss and Converse."

PUBLIC UTILITY DISTRICT #2 OF GRANT COUNTY	Date	09/26/77	MULTI-CONDUCTOR, UG, 600V, ALUMINUM	ASSEMBLY UNIT		Yes		
	Rev #	6		SOLE SOURCE		No		
	Designer	JB		TDSI	X	TTNI	TMNI	TSNI
	Standards Engineer			09102004				
AL SILVA								